

PTA80-IY TIME-ALIGN®

SELF-POWERED

APPLICATIONS

Audio-Visual Installations	House of Worship Installations
Front Fill for Large Systems	Restaurant Foreground Music Systems
Auditorium Under Balcony Fill	Fitness Centers
Nightclub Installations	Surround Sound Systems

DESCRIPTION

The PTA80-IY produces high definition high impact sound over its wide angle making audience coverage easy and effective in a variety of venues. A compact loudspeaker, engineered for exceptional mid field and near field performance, it is well known for exceptional fidelity and its surprisingly high output capability.

Useful for foreground and background music applications, it also excels for speech projection and small PA systems. With its fidelity, size and output the PTA80-IY is perfect for multi channel 5.1 presentations systems. In larger audio systems it is highly effective as a fill, delay or under balcony speaker. The addition of a Bag End subwoofer will expand its capabilities for more demanding applications.

The conical high frequency waveguide produces a uniform horizontal and vertical coverage pattern and the included steel mounting yoke U-Bracket enables vertical or horizontal mounting for easily installation and aiming.



SPECIFICATIONS

System Type:

2-way vented 0.6 ft³

Enclosure:

3/4" MDF

Finish:

Black Ro Tex™ True water born environmental finish

Grille:

18 Gauge black powder coated perforated steel

Low Frequency Components:

E-8A 8" Driver, 2" Voice coil,
34 oz. Magnet

High Frequency Components:

E-100 1" Exit compression driver,
1" Mylar diaphragm, Ceramic. Magnet,
Hybrid Conical Waveguide

Input Connector:

XLR Female
Mounted on back

Input Impedance:

10K Ohms

Maximum Continuous Amplifier Power:

200 W into 8 Ohms

Mains Voltage Requirements:

Auto sensing
120 / 240 Volts

Mains Current Requirements:

2.3 Amps @ 120 Volts
1.2 Amps @ 240 Volts

Hardware:

Yoke-TA80
Steel Yoke U-bracket

Crossover Type:

Passive Time-Align® equalizer type at 2.8 kHz

Time Offset Between Driver:

< ± 25 Microseconds

Frequency Response:

100 Hz to 20 kHz ±3 dB

Low Frequency Limit:

80 Hz

Maximum Calculated Continuous Acoustic Output:

120 dB SPL @ 1m

Coverage Pattern:

90 degrees Horizontal (-6 dB)
90 degrees Vertical (-6 dB)

Recommended High Pass Filter:

80 Hz

Polarity:

A positive asymmetrical signal applied to the + terminal will result in a positive asymmetrical acoustical pressure

Dimensions:

14"h x 10"w x 11.5"d
35 cm x 25 cm x 29 cm

Weight:

34 lbs
15 kg

Custom Finishes:

Optional custom finishes include white or unfinished ready to paint.

TIME-ALIGN®, TIME-ALIGNED™ and TIME-ALIGNMENT™ are trademarks of E.M. Long Associates.
BAG END® is a registered trademark of Bag End, Inc.



PTA80-IY TIME-ALIGN®

ABOUT TIME-ALIGN® TECHNOLOGY

Time-Align® assures that the fundamental and overtones of a complex, transient, acoustical signal are presented to the listener in the same relationship as the electrical signal at the input terminals of the loudspeaker. The conventional loudspeaker spreads out the sound in time. When a rapid series of transients occur the results are blurring and lost detail. With Time-Align®, a transient is presented as a tight package of energy, with the same time relationships as the natural sound. This means that a rapid series of transients will be heard clearly.



True Time-Alignment™ requires much more than just physically lining up the loudspeaker components. It requires consideration of the driver placement, driver delay and adjustment of the crossover delay parameters. This achieves the precise simultaneous acoustical arrival time of each driver throughout the crossover region.

The first Time-Aligned™ Loudspeaker was invented by EM Long Associates in 1976 utilizing the Time-Align® generator invented and built by Ronald Wickersham. In 1980 Bag End® incorporated Time-Align® technology into our full range loudspeaker systems. Along with state-of-the-art laboratory instruments, the proprietary Time-Align® generator is still in use today to verify the time domain performance of our loudspeaker systems. When comparing a genuine Bag End® Time-Aligned™ loudspeaker system to any other, our technology and design is easy to hear and appreciate. The dramatic clarity, realism, and overall pleasant sound of our Time-Aligned™ systems are well noted worldwide.

ABOUT OUR RO TEX™ FINISH

The durable Ro Tex™ finish is double layered on Bag End™ "R" series or Road cabinets. And single layered on installation or "I" cabinets. Ro Tex™ is a water born environmentally safe finish. It's uniquely strong and long

lasting. As it solidifies it attaches and bonds to the wooden cabinet to make a super hard and durable permanent finish. Its light texture offers an attractive and rugged finished look

ABOUT BAG END® LOUSPEAKERS

Bag End loudspeakers began in 1976 in a small shop by people dedicated to the pursuit of making high quality loudspeaker systems. Over the decades Bag End® has employed the very best construction techniques and innovative acoustical designs into their products. The ground breaking introductions of the Time-Align® and ELF™ Technologies into sound reinforcement and studio monitor loudspeakers in the 1980's was followed by Minima One™ self-powered systems and the highly unique E-Trap™, electronic bass trap. Over the decades, Bag End® has been a leader in providing uniquely good sounding products and extraordinary service to our customers world wide.

DIMENSIONS

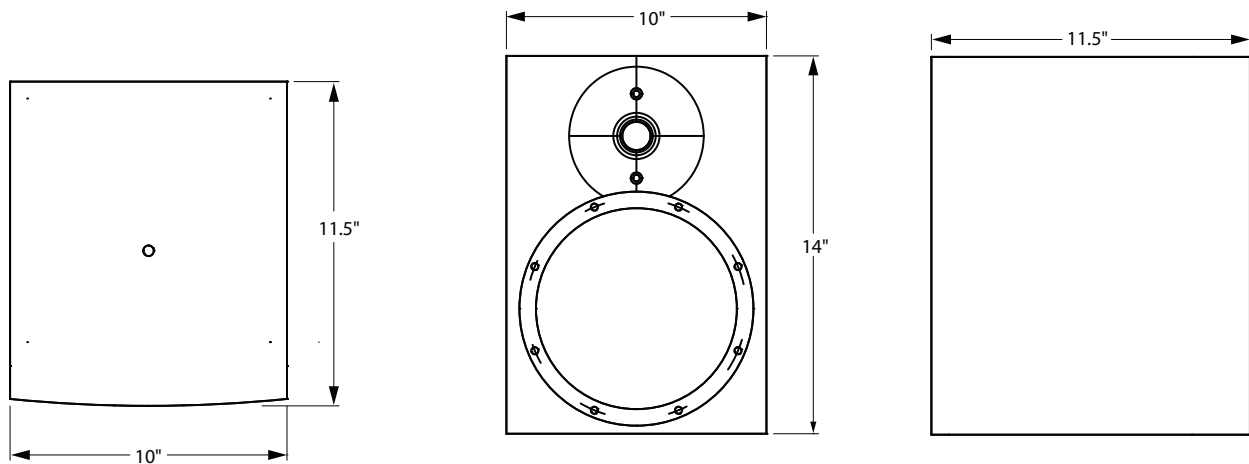

○ = 5/16" - 18 Threaded Rigging Point

