

# IPS18E-I INFRASUB™

SELF-POWERED & SELF INFRA™ PROCESSED

## APPLICATIONS

Laboratory Reference System	House of Worship
Recording Studio and Mastering	Theatrical Sound Reinforcement
Post Production and Screening Room	Nightclub Installation
Cinema Subwoofer	Surround Sound Low Frequency Effects

## DESCRIPTION

The IPS18E-I is a self-powered and internally Infra™ processed single 18" bass system designed for permanent installation. The internal Minima One™ amplifier and Infra™ processing provides for convenient implementation and wiring. The internal Infra™ integrator, amplifier and loudspeaker process the full range signal into a flat response low frequency acoustic output. The Dynamic Filter™ protection threshold is internally preset to eliminate distortion or accidental overload. This insures the maximum output and robust system protection with virtually no audible effect.

The audio input incorporates an InGenius® balanced line receiver, providing very high common mode rejection, to eliminate noise often present in systems with less optimized grounding and wiring schemes. Low voltage contacts are provided to remotely turn the amplifier on and off.



## SPECIFICATIONS

### System Type:

Infrasub™ sealed chamber 3 ft<sup>3</sup>

### Enclosure:

18 mm 13-ply birch plywood

### Finish:

Black Ro Tex™ True water born environmental finish

### Grille:

16 Gauge black power coated perforated steel

### Low Frequency Components:

EL-18A 18" Extended Transducer, Infra™ cone, 3" Voice coil, 120 oz. Magnet

### Input Connector:

XLR 1/4" combo with XLR loop through

### Internal Amplification:

Minima One™

### Input Impedance:

48K Ohms

### Input CAL Sensitivity:

+4 dBu

### Maximum Continuous Amplifier Power:

1350 W into 4 Ohms

### High Pass Filter:

Switchable: -6 dB @ 8 Hz; @ 50 Hz; @ 95 Hz

### LED Indicators:

Green - On  
Yellow - Dynamic filter threshold  
Red - System fault or sleep mode

### Mains Voltage Requirements:

Auto sensing  
Universal voltage range  
88 Volts minimum to 270 Volts maximum

### Mains Current Requirements:

2.3 Amps @ 120 Volts  
1.2 Amps @ 240 Volts

### Hardware:

4 - Machined aluminum speaker mounting clamps  
Optional F4 rigging points available

### Fly Points Safe Working Load:

200 lbs.

### Crossover Type:

Internal Infra™ Integrator Inside

### Frequency Response:

8 Hz to 95 Hz ±3 dB

### Low Frequency Limit:

8 Hz

### Maximum Calculated Continuous Acoustic Output:

Half Space @ 1 Meter  
10 Hz - 89 dB SPL  
20 Hz - 101 dB SPL  
40 Hz - 113 dB SPL  
80 Hz - 124 dB SPL

### Polarity:

A positive asymmetrical signal applied to pin 2 will result in a positive asymmetrical acoustical pressure

### Dimensions:

21" h x 22" w x 18" d  
54 cm x 56 cm x 46 cm

### Weight:

69 lbs  
31 kg

### Custom Finishes:

Optional custom finishes include white or unfinished ready to paint.

INFRA™, INFRASUB™, MINIMA ONE™ and DYNAMIC FILTER™ are trademarks of Modular Sound Systems, Inc.  
BAG END® is a registered trademark of Bag End, Inc.

# IPS18E-1 INFRASUB™

## ABOUT INFRASUB™ TECHNOLOGY

Almost all designs and specifications for subwoofer systems are fixated on the frequency response domain. However, the impression of power and quality of a loudspeaker is equally related to the time domain. The long wavelengths associated with low frequencies make this particularly true with subwoofers. Likewise, the maximum SPL is not a very reliable way to judge the impact of a subwoofer. A poor time domain performer will not have the same impact or natural musically connected sound as a Time-Aligned™ Infra™ system. The reason that an Infra™ subwoofer sounds dramatically better is because of their superior time domain performance, as well as their extended low

frequency response. The Infra™ subwoofer maintains the bass energy in a tight packet, aligned with the upper range signal, providing a greater body impact and a seamless musical connection with the main loudspeakers. Conventional subwoofer designs perform so poorly in the time domain because designers have used methods that sacrifice the phase response for more control over the frequency response (e.g.: steep low pass filter slopes, vented speaker enclosures, and narrow bandwidth systems). With the Infra™ technique, we do not degrade the phase response while extending the frequency response.

While the Infra™ dual Integrator does function as the system crossover, it does so without using a conventional low pass filter. The Infra™ integrator applies an inverse electrical response to the acoustical response of the Infra™ loudspeaker in its sealed enclosure. This provides the extended frequency response while maintaining the hi sound quality often associated with a sealed box design. This design approach requires the most amplifier power to be used at the lowest frequency, thus we implement the Dynamic Filter™ technology to protect the system from the bottom up, affecting the lowest frequency first and leaving the middle and upper bass unaffected. The Dynamic Filter™ is a complimentary technology to the Infra™ system taking unique advantage of the Infra™ design approach, to implement a reliable protection

scheme that is transparent and inaudible to the listener. When comparing a genuine Bag End® Infra™ loudspeaker system to any other, our technology and design is easy to hear and appreciate. The dramatic clarity, realism, and overall pleasant sound of an Infra™ system is well noted throughout the world.

## ABOUT MINIMA ONE™ AND INFRA™ SELF PROCESSING

Infra™ self processed systems incorporates our analog Infra™ dual integrator into the Minima One™ input circuit. Infra™ Self Powered Systems accept a full range line level audio signal, and utilizes internal Infra™ processing to provide the extended low frequency acoustical response, as well as a uniform roll off, of the upper range of the subwoofer. The Dynamic Filter™ protection is included and preset to the amplifiers sensitivity, requiring no external setup. The Minima One™ amplifier is both a high fidelity and a high efficiency amplifier. With efficiency well over 80%, it provides more power to the loudspeakers, and creates less heat in the amplifier. In real world applications there is practically no heat emitted from the amplifier and thus it requires no cooling fan. The power factor corrected AC power input, automatically and continuously adapts to any voltage between 88 and 270 volts. The Minima One™ is convenient and stable to operate on any power grid in the world.



## DIMENSIONS

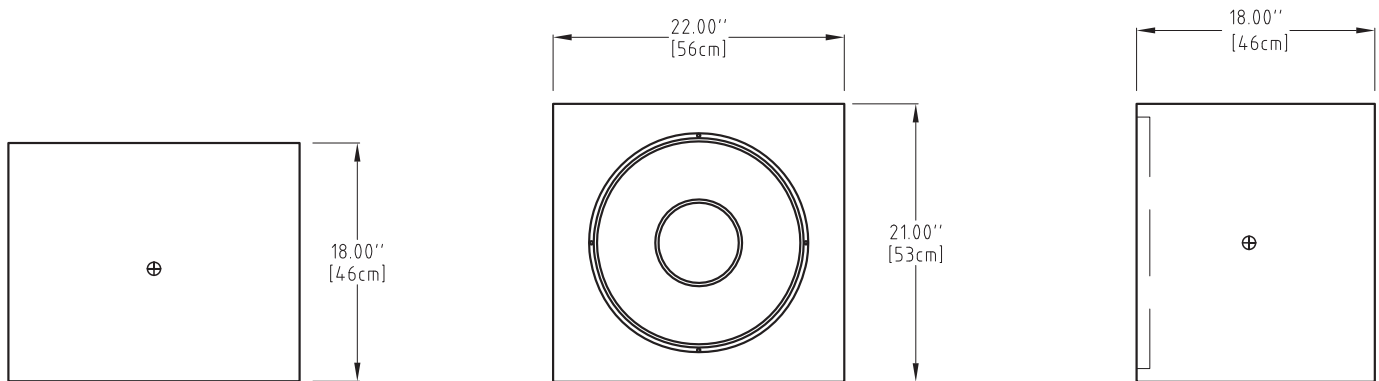

⊕ = Center of Gravity

# IPS18E-1 INFRASUB™

## SIDE VIEW

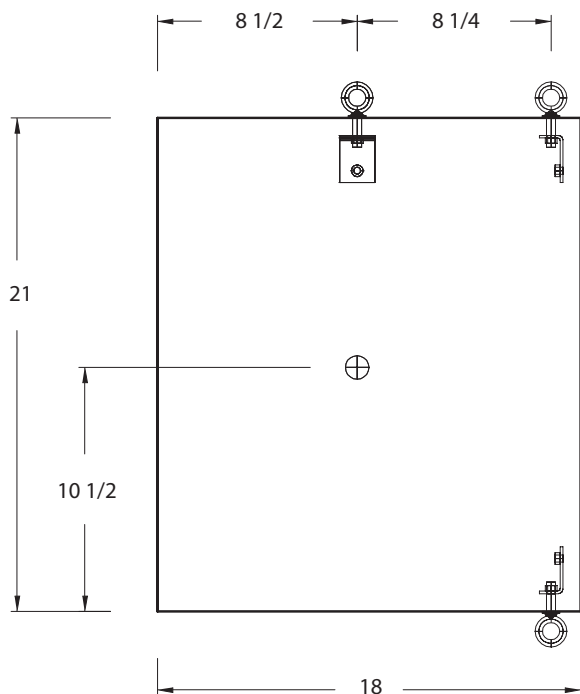

## ISOMETRIC VIEW

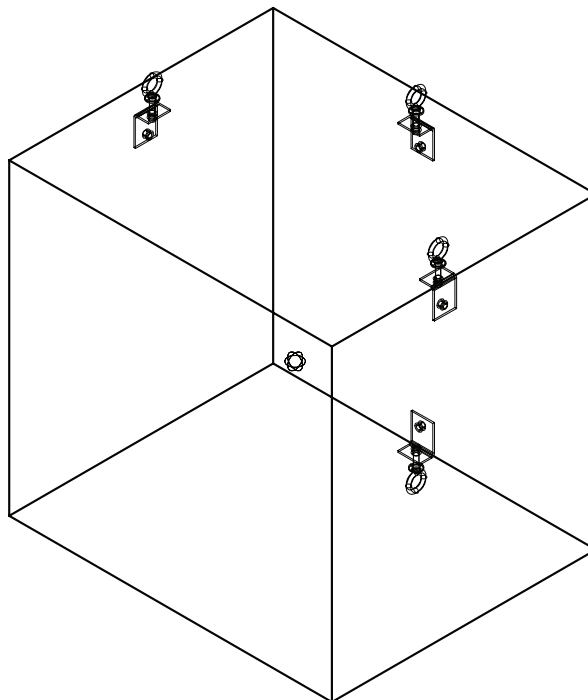

## TOP VIEW

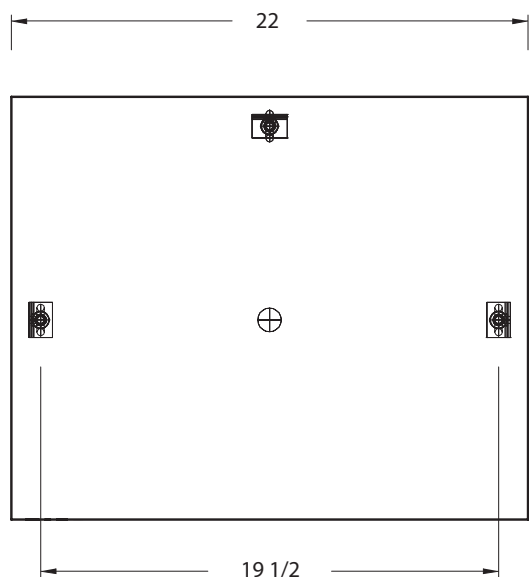

## KEY

Center of Gravity: +

## WARNINGS

Mounting and rigging loudspeakers requires experienced professionals. Improperly installed loudspeakers can result in property damage, personal injury, death and/or liability to the installing contractor.

## FLYPOINTS

This optional hardware packet includes flypoints as shown plus 3 x 5/16" - 18 forged shoulder eyebolts