

CD-12 VENUS

APPLICATIONS

Auditorium Sound Reinforcement	House of Worship Installations
Installed Audio-Visual Systems	Theatrical Sound Reinforcement
Portable DJ Systems	Nightclub Installations
Portable Sound Reinforcement	Vocal Monitor

DESCRIPTION

The CD-12 produces high definition, high impact sound over its controlled coverage angle, allowing precise effective audience coverage in a variety of applications. This point source loudspeaker, engineered for exceptional mid field and long throw performance, is known for its extraordinary fidelity and extremely high output. In addition to live performance venues it excels in music playback and stage monitoring applications. The multiple angle design along with the rotatable 90 degree (h) by 60 degree (v) coverage pattern offers optimal mounting and coverage options when up against walls and ceilings or a choice of angles when used as a stage monitor.

The CD-12 is configured for bi-amp mode and utilizes the Bag End® Karios KS26 DSP processor including presets for crossover, EQ, Time-Align and system limiting protection. Its uniform controlled directivity, surprisingly powerful bass and Time-Align fidelity, coupled with its small size and hi output, makes it perfect for most stand alone applications.

Constructed from 15mm Baltic Birch plywood the CD-12 features a durable and attractive black Ro Tex finish, durable steel grille, Integral handles, an internal stand adapter and M10 attachment points.



SPECIFICATIONS

System Type:

2-way vented 3.4 ft³

Enclosure:

15 mm 11-ply birch plywood

Finish:

Black Ro Tex™ true water born environmental finish

Grille:

14 Gauge black powder coated perforated steel

Low Frequency Components:

E-12F Transducer, 12" Cone, 2.5" Voice coil, Neodymium magnet

High Frequency Components:

E-806 Transducer, 1.4" Exit Neodymium compression driver, CD Controlled directivity waveguide

Input Connector:

Dual Neutrik® speakON

Internal Amplification:

Optional self powered

Hardware:

Fly points
Optional steel yoke model CD12

Fly Points Safe Working Load:

200 lbs Upper most rigging points

Crossover Type:

Bi amp only requires DSP

Sensitivity:

95 dB SPL (2.83 V @ 1 m)

Frequency Response:

60 Hz - 20 kHz

Low Frequency Limit:

49 Hz (-10 dB)

Maximum Calculated Continuous Acoustic Output:

128 dB SPL @ 1 m

Power Handling:

Low: 300 W continuous (AES) 600 W program
High: 125 W continuous (AES) 250 W program

Recommended Amplifier Power:

Low: 600 W at rated impedance
High: 250 W at rated impedance

Rated Impedance:

Low: 8 ohms
High: 16 ohms

Coverage Pattern:

500 Hz – 16 kHz
105 degrees x 75 degrees

Q 500 Hz – 16 kHz:

9.1

Di 500 Hz – 16 kHz:

9.3 dB

Recommended High Pass Filter:

55 Hz Butterworth 18 dB/octave

Polarity:

A positive asymmetrical signal applied to the + terminal will result in a positive asymmetrical acoustical pressure

Dimensions:

25.25" h x 14.5" w x 13.75" d
64 cm x 36 cm x 35 cm

Weight:

44 lbs
20 kg

Custom Finishes:

Optional custom finishes include white, unfinished ready to paint and outdoor weather treatment.

TIME-ALIGN®, TIME-ALIGNED™ and TIME-ALIGNMENT™ are trademarks of E.M. Long Associates.
BAG END® is a registered trademark of Bag End, Inc.

CD-12 VENUS

ABOUT TIME-ALIGN® TECHNOLOGY

Time-Align® assures that the fundamental and overtones of a complex, transient, acoustical signal are presented to the listener in the same relationship as the electrical signal at the input terminals of the loudspeaker. The conventional loudspeaker spreads out the sound in time. When a rapid series of transients occur the results are blurring and lost detail. With Time-Align®, a transient is presented as a tight package of energy, with the same time relationships as the natural sound. This means that a rapid series of transients will be heard clearly.



True Time-Alignment™ requires much more than just physically lining up the loudspeaker components. It requires consideration of the driver placement, driver delay and adjustment of the crossover delay parameters. This achieves the precise simultaneous acoustical arrival time of each driver throughout the crossover region.

The first Time-Aligned™ Loudspeaker was invented by EM Long Associates in 1976 utilizing the Time-Align® generator invented and built by Ronald Wickersham. In 1980 Bag End® incorporated Time-Align® technology into our full range loudspeaker systems. Along with state-of-the-art laboratory instruments, the proprietary Time-Align® generator is still in use today to verify the time domain performance of our loudspeaker systems. When comparing a genuine Bag End® Time-Aligned™ loudspeaker system to any other, our technology and design is easy to hear and appreciate. The dramatic clarity, realism, and overall pleasant sound of our Time-Aligned™ systems are well noted worldwide.

to make a super hard permanent finish. It is lightly textured offering both an attractive and rugged finish.

ABOUT BAG END® LOUSPEAKERS

Bag End loudspeakers began in 1976 in a small shop by people dedicated to the pursuit of making high quality loudspeaker systems. Over the decades Bag End® has employed the very best construction techniques and innovative acoustical designs into their products. The ground breaking introductions of the Time-Align® and ELF™ Technologies into sound reinforcement and studio monitor loudspeakers in the 1980's was followed by Minima One™ self-powered systems and the highly unique E-Trap™, electronic bass trap. Over the decades, Bag End® has been a leader in providing uniquely good sounding products and extraordinary service to our customers world wide.

ABOUT OUR RO TEX™ FINISH

The durable Ro Tex™ finish is found on Bag End™ "R" series or Road cabinets. Ro Tex™ is a water base, environmentally safe finish that is made in Europe and is uniquely strong and long lasting. As it solidifies and attaches to the wooden cabinet it bonds with the wood

DIMENSIONS

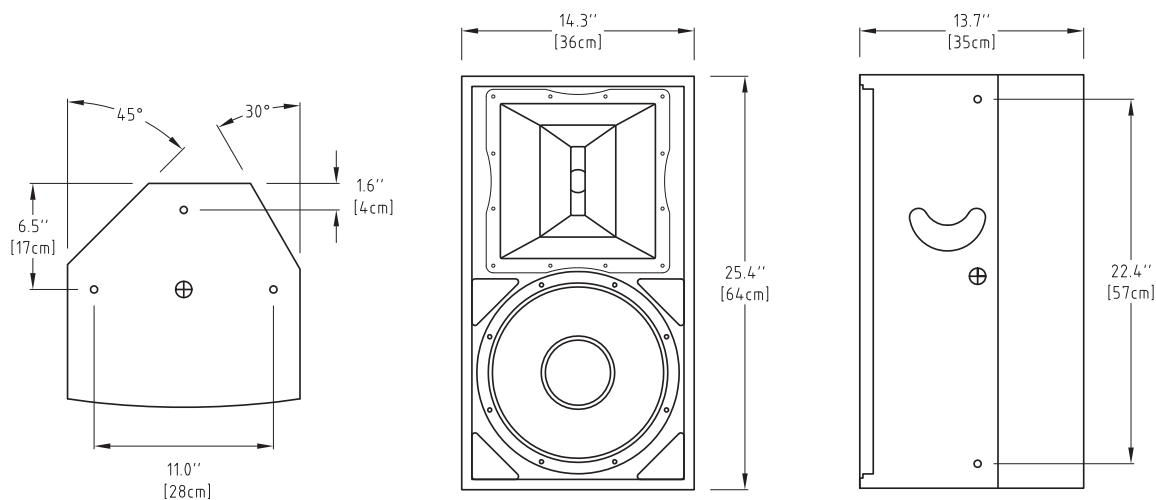

⊕ = Center of Gravity ○ = M10 Threaded Rigging Point