

CD-B18 VENUS

APPLICATIONS

Auditorium Sound Reinforcement	House of Worship Installations
Sports Facilities	Theatrical Sound Installations
Audio-Visual Systems	Nightclub Installations
Portable Sound Reinforcement	Low Frequency Special Effects

DESCRIPTION

The CD-B18 is a high output low frequency loudspeaker system designed to provide superior output and fidelity for extended low frequency audio reproduction. The CDB-18 incorporates our proprietary tuned, damped, OPTM alignment, providing greater output and less distortion as compared to standard venting. Artifacts and vent turbulence, even at extreme levels, are reduced. This makes the CD-B18 an ideal choice for high level systems requiring stability and reliability under the most demanding long term use. Designed for portable use, the CD-B18 is constructed from 18mm Baltic birch plywood and features a durable and attractive black Ro Tex™ finish, durable steel grille, integral handles and a stand adapter.



SPECIFICATIONS

System Type:

Vented

Enclosure:

18 mm 13-ply birch plywood

Finish:

Black Ro Tex™ true water born environmental finish

Grille:

14 Gauge black powder coated perforated steel

Low Frequency Components:

E-18C Transducer, 18" Cone, 4" Voice coil

Input Connector:

Dual Neutrik® speakON

Internal Amplification:

Optional self powered

Crossover Type:

Requires DSP

Sensitivity:

95 dB SPL (2.83 V @ 1 m)

Frequency Response:

40 Hz - 200 Hz

Low Frequency Limit:

34 Hz (-10 dB)

Power Handling:

1200 W continuous (AES) 2400 W program

Recommended Amplifier Power:

1200 to 2400 W at rated impedance

Rated Impedance:

8 ohms

Polarity:

A positive asymmetrical signal applied to the + terminal will result in a positive asymmetrical acoustical pressure

Dimensions:

25.5" h x 20" w x 30" d
65 cm x 50 cm x 76 cm

Weight:

108 lbs
49 kg

Custom Finishes:

Optional custom finishes include white, unfinished ready to paint and outdoor weather treatment.

BAG END® is a registered trademark of Bag End, Inc.

CD-B18 VENUS

ABOUT OUR RO TEX™ FINISH

The durable Ro Tex™ finish is found on Bag End™ "R" series or Road cabinets. Ro Tex™ is a water base, environmentally safe finish that is made in Europe and is uniquely strong and long lasting. As it solidifies and attaches to the wooden cabinet it bonds with the wood to make a super hard permanent finish. It is lightly textured offering both an attractive and rugged finish.

ABOUT BAG END® LOUDSPEAKERS

Bag End loudspeakers began in 1976 in a small shop by people dedicated to the pursuit of making high quality loudspeaker systems. Over the decades Bag End® has employed the very best construction techniques and innovative acoustical designs into their products. The ground breaking introductions of the Time-Align® and ELF™ Technologies into sound reinforcement and studio monitor loudspeakers in the 1980's was followed by Minima One™ self-powered systems and the highly unique E-Trap™, electronic bass trap. Over the decades, Bag End® has been a leader in providing uniquely good sounding products and extraordinary service to our customers world wide.



DIMENSIONS

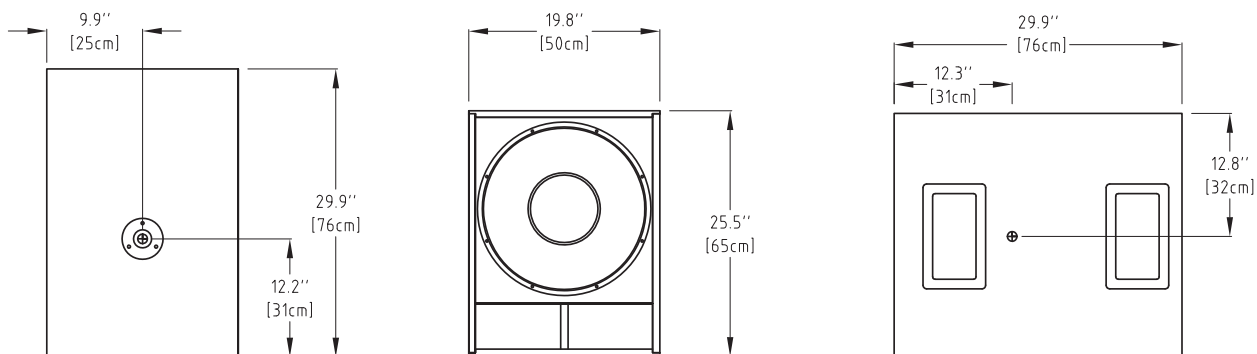

⊕ = Center of Gravity ⊙ = M10 Threaded Rigging Point