

PS18E-I INFRASUB™

SELF-POWERED

APPLICATIONS

Laboratory Reference System	House of Worship
Recording Studio and Mastering	Theatrical Sound Reinforcement
Post Production and Screening Room	Nightclub Installation
Cinema Subwoofer	Surround Sound Low Frequency Effects

DESCRIPTION

The PS18E-I is a self-powered single 18" bass system designed for permanent installation. The PS18E-I provides perfectly flat response down to 8 hertz when used in conjunction with the 8 hertz Integrator. Our external rack mount Infra-MXB Integrator is recommended to drive a line level Infra™ processed signal to one or more PS18E-I systems. The PS18E-I offers a black textured finish and a black coated steel grille.

The audio input incorporates an InGenius® balanced line receiver, providing very high common mode rejection, to eliminate noise often present in systems with less optimized grounding and wiring schemes. The internal Minima 7™ amplifier incorporates a high efficiency low power consumption green design with advanced digital switching to automatically switch and accept line voltage from 100 to 240 volts.



SPECIFICATIONS

System Type:

Infrasub™ sealed chamber 3 ft³

Enclosure:

18 mm 13-ply birch plywood

Finish:

Black Ro Tex™ true water born environmental finish

Grille:

16 Gauge black powder coated perforated steel

Low Frequency Components:

EL-18A 18" Extended transducer, INFRA™ cone, 3" Voice coil, 120 oz Magnet

Input Connector:

XLR 1/4" combo with XLR loop through

Internal Amplification:

Minima 7™

Input Impedance:

48K ohms

Input CAL Sensitivity:

+4 dBu

Maximum Continuous Amplifier Power:

750 W

High Pass Filter:

Switchable: -6 dB @ 8 Hz; @ 50 Hz; @ 95 Hz

Overload Protection:

Internal Dynamic Filter™ protection

LED Indicators:

Green - On
Yellow - Dynamic filter threshold

Mains Voltage Requirements:

Auto sensing
100 / 120 / 240 V

Mains Current Requirements:

2.3 A @ 120 V
1.2 A @ 240 V

Hardware:

Optional fly points
Optional steel yoke U-bracket

Fly Points Safe Working Load:

200 lbs

Crossover Type:

Requires external Infra™ integrator

Frequency Response:

60 Hz to 250 Hz ±3 dB
8 Hz to 95 Hz ±3 dB with external Infra™ integrator

Low Frequency Limit:

8 Hz

Maximum Calculated Continuous Acoustic Output:

Half Space @ 1 Meter
10 Hz - 89 dB SPL
20 Hz - 101 dB SPL
40 Hz - 113 dB SPL
80 Hz - 124 dB SPL

Maximum Continuous Acoustic Output:

To be added

Polarity:

A positive asymmetrical signal applied to pin 2 will result in a positive asymmetrical acoustical pressure

Dimensions:

21" h x 22" w x 18" d
54 cm x 56 cm x 46 cm

Weight:

65 lbs
29 kg

Custom Finishes:

Optional custom finishes include white or unfinished ready to paint.

INFRA™, INFRASUB™, MINIMA 7™ and DYNAMIC FILTER™ are trademarks of Modular Sound Systems, Inc.
BAG END® is a registered trademark of Bag End, Inc.



PS18E-I INFRASUB™

About INFRASUB™ Technology

Almost all designs and specifications for subwoofer systems are fixated on the frequency response domain. However, the impression of power and quality of a loudspeaker is equally related to the time domain. The long wavelengths associated with low frequencies make this particularly true with subwoofers. Likewise, the maximum SPL is not a very reliable way to judge the impact of a subwoofer. A poor time domain performer will not have the same impact or natural musically

connected sound as a Time-Aligned™ Infra™ system. The reason that an Infra™ subwoofer sounds dramatically better is because of their superior time domain performance, as well as their extended low frequency response. The Infra™ subwoofer maintains the bass energy in a tight packet, aligned with the upper range signal, providing a greater body impact and a seamless musical connection with the main loudspeakers. Conventional subwoofer designs perform poorly in the time domain because designers have used methods that sacrifice the phase response for more control over the frequency response (e.g.: steep low pass filter slopes, vented speaker enclosures, and narrow bandwidth systems). With the Infra™ technique, we do not degrade the phase response while extending the frequency response.

While the Infra™ dual Integrator does function as the system crossover, it does so without using a conventional low pass filter. The Infra™ integrator applies an inverse electrical response to the acoustical response of the Infra™ loudspeaker in its sealed enclosure. This provides the extended frequency response while maintaining the hi fidelity sound quality associated with a sealed box design. This design approach requires the most amplifier power to be used at the lowest frequency, thus we implement the Dynamic Filter™ technology to protect the system from the bottom

up, affecting the lowest frequency first and leaving the middle and upper bass unaffected. The Dynamic Filter™ is a complimentary technology to the Infra™ system taking unique advantage of the Infra™ design approach, to implement a reliable protection scheme that is transparent and inaudible to the listener. When comparing a genuine Bag End® Infra™ loudspeaker system to any other, our technology and design is easy to hear and appreciate. The dramatic clarity, realism, and overall pleasant sound of an Infra™ system is well noted throughout the world.

About Minima 7™ Self Powered

The Minima 7™ amplifier is both a high fidelity and a high efficiency amplifier. With efficiency well over 80%, it provides more power to the loudspeakers, and creates less heat in the amplifier. In real world applications there is practically no heat emitted from the amplifier and thus it requires no cooling fan. The AC power input automatically adapts to any voltage between 88 and 270 volts.



DIMENSIONS

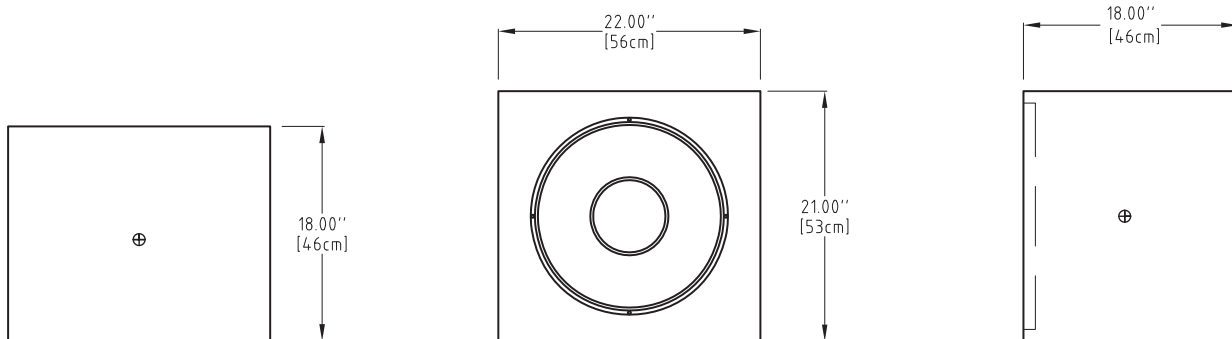

⊕ = Center of Gravity

PS18E-1 INFRASUB™

SIDE VIEW

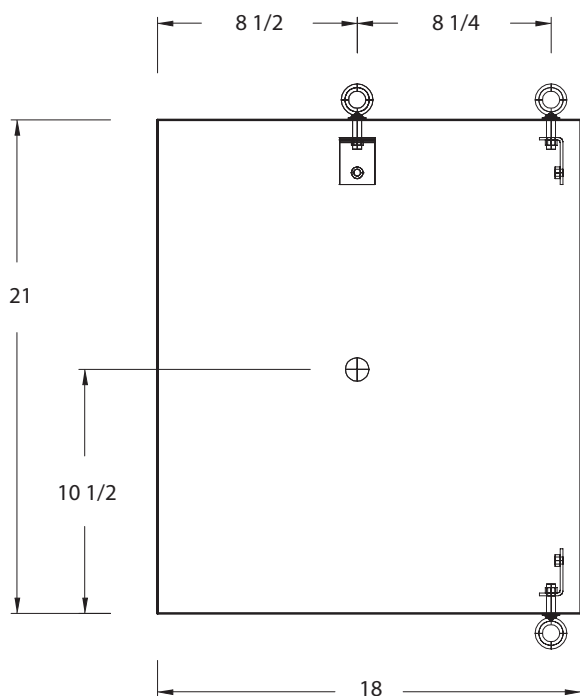

ISOMETRIC VIEW

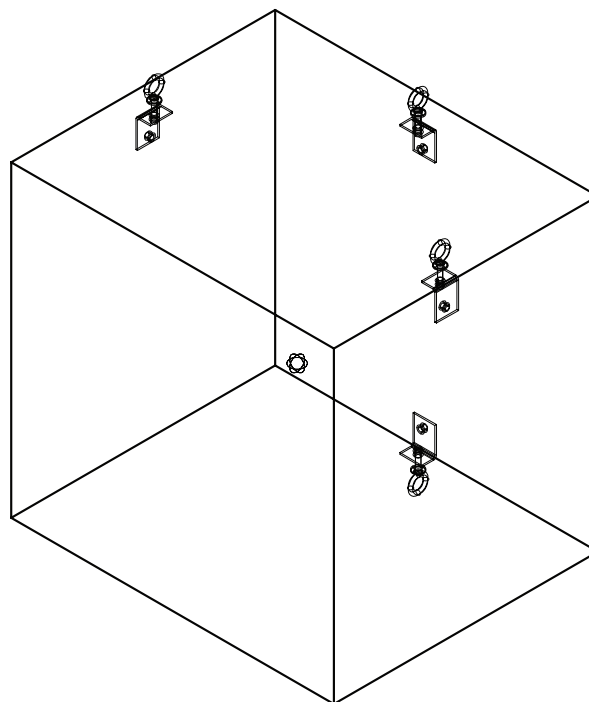

TOP VIEW

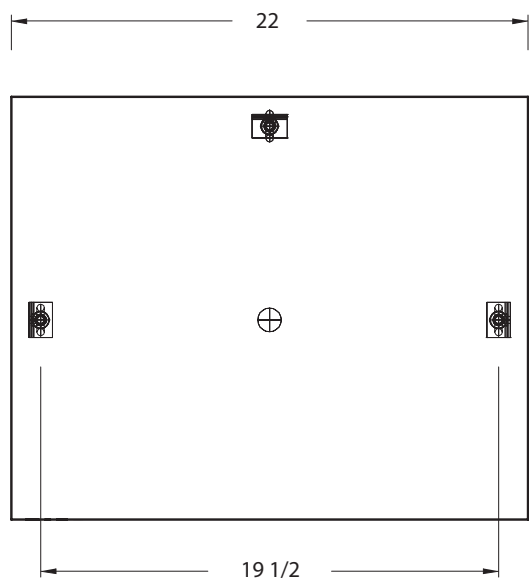

Key

Center of Gravity: +

Warnings

Mounting and rigging loudspeakers requires experienced professionals. Improperly installed loudspeakers can result in property damage, personal injury, death and/or liability to the installing contractor.

Flypoints

Optional hardware includes 5/16-18 threaded flypoints as shown.