

PTA1202-R TIME-ALIGN®

SELF-POWERED

APPLICATIONS

Portable Sound Reinforcement Portable DJ Systems
Portable Audio-Visual Systems Electronic Keyboards
Theatrical Sound Reinforcement

DESCRIPTION

The PTA1202-R is a self-powered Minima 7™, full range, portable loudspeaker system offering both high fidelity and high efficiency. The Time-Aligned™ studio quality sound provides detail and clarity not found in other designs. The PTA1202-R is made from durable birch plywood with a black Ro Tex™ finish and includes a stand adapter and recessed handles.

The audio input incorporates an InGenius® balanced line receiver providing very high common mode rejection to eliminate noise often present in systems with less optimized grounding and wiring schemes. The internal Minima 7™ amplifier incorporates a high efficiency low power consumption green design with advanced digital switching to automatically switch and accept line voltage from 100 to 240 volts.

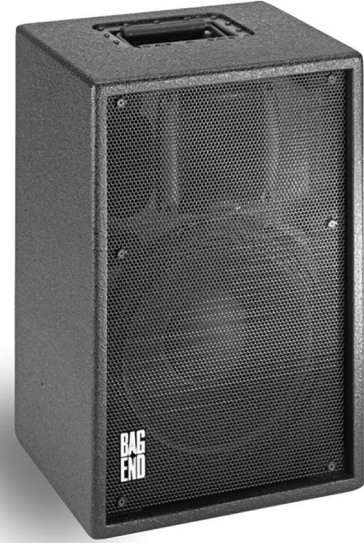

SPECIFICATIONS

System Type:

2-way vented 2 ft³

Enclosure:

18 mm 13-ply birch plywood

Finish:

Black Ro Tex™ true water born environmental finish

Grille:

16 Gauge black powder coated perforated steel

Low Frequency Components:

SE-1280 12" Transducer, 2.5" Voice coil, 80 oz Magnet

High Frequency Components:

E-700 1" Exit compression driver, 1.8" Titanium diaphragm, 15 oz Magnet, Radial waveguide

Input Connector:

XLR 1/4" combo with XLR loop through

Internal Amplification:

Minima 7™

Input Impedance:

48K ohms

Input CAL Sensitivity:

+4 dBu

Maximum Continuous Amplifier Power:

750 W

High Pass Filter:

Switchable: -6 dB @ 8 Hz; @ 50 Hz; @ 95 Hz

Overload Protection:

Internal limiter

LED Indicators:

Green - On
Yellow - System limit

Mains Voltage Requirements:

Auto sensing
100 / 120 / 240 V

Mains Current Requirements:

2.3 A @ 120 V
1.2 A @ 240 V

Hardware:

Recessed handle
35 mm Stand adapter

Crossover Type:

Passive Time-Align® equalizer type at 2.5 kHz

Time Offset Between Driver:

< ± 25 Microseconds

Frequency Response:

75 Hz to 20 kHz ±3 dB

Low Frequency Limit:

60 Hz

Maximum Calculated Continuous Acoustic Output:

127 dB SPL @ 1 m

Coverage Pattern:

80 degrees horizontal (-6 dB)
60 degrees vertical (-6 dB)
Rotatable horn

Polarity:

A positive asymmetrical signal applied to pin 2 will result in a positive asymmetrical acoustical pressure

Dimensions:

21" h x 14" w x 11.5" d
54 cm x 36 cm x 30 cm

Weight:

49 lbs
22 kg

Custom Finishes:

Optional custom finishes include white or unfinished ready to paint.

TIME-ALIGN®, TIME-ALIGNED™ and TIME-ALIGNMENT™ are trademarks of E.M. Long Associates.
MINIMA 7™ is a trademark of Modular Sound Systems, Inc., BAG END® is a registered trademark of Bag End, Inc.



PTA1202-R TIME-ALIGN®

ABOUT TIME-ALIGN® TECHNOLOGY

Time-Align® assures that the fundamental and overtones of a complex, transient, acoustical signal are presented to the listener in the same relationship as the electrical signal at the input terminals of the loudspeaker. The conventional loudspeaker spreads out the sound in time. When a rapid series of transients occur the results are blurring and lost detail. With Time-Align®, a transient is presented as a tight package of energy, with the same time relationships as the natural sound. This means that a rapid series of transients will be heard clearly.

True Time-Alignment™ requires much more than just physically lining up the loudspeaker components. It

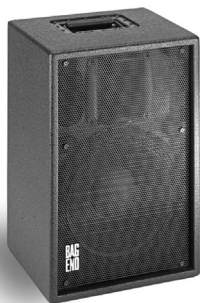

requires consideration of the driver placement, driver delay and adjustment of the crossover delay parameters. This achieves the precise simultaneous acoustical arrival time of each driver throughout the crossover region.

The first Time-Aligned™ Loudspeaker was invented by EM Long Associates in 1976 utilizing the Time-Align® generator invented and built by Ronald Wickersham. In 1980 Bag End® incorporated Time-Align® technology into our full range loudspeaker systems. Along with state-of-the-art laboratory instruments, the proprietary Time-Align® generator is still in use today to verify the time domain performance of our loudspeaker systems. When comparing a genuine Bag End® Time-Aligned™ loudspeaker system to any other, our technology and design is easy to hear and appreciate. The dramatic clarity, realism, and overall pleasant sound of our Time-Aligned™ systems are well noted worldwide.

ABOUT MINIMA 7™ SELF POWERED

The Minima 7™ amplifier is both a high fidelity and a high efficiency amplifier. With efficiency well over 80%, it provides more power to the loudspeakers, and creates less heat in the amplifier. In real world applications there

is practically no heat emitted from the amplifier and thus it requires no cooling fan. The AC power input automatically adapts to any voltage between 88 and 270 volts.

ABOUT BAG END® LOUSPEAKERS

Bag End loudspeakers began in 1976 in a small shop by people dedicated to the pursuit of making high quality loudspeaker systems. Over the decades Bag End® has employed the very best construction techniques and innovative acoustical designs into their products. The ground breaking introductions of the Time-Align® and ELF™ Technologies into sound reinforcement and studio monitor loudspeakers in the 1980's was followed by Minima One™ self-powered systems and the highly unique E-Trap™, electronic bass trap. Over the decades, Bag End® has been a leader in providing uniquely good sounding products and extraordinary service to our customers world wide.

DIMENSIONS

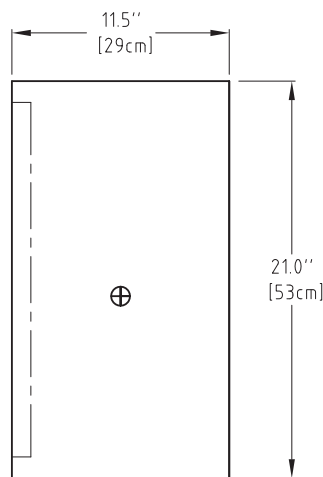
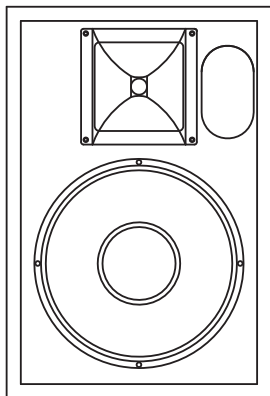
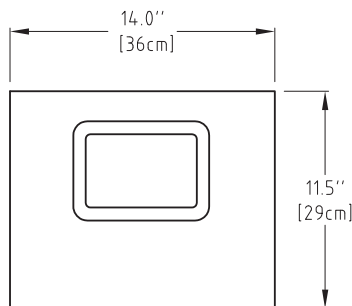

⊕ = Center of Gravity