

PTA2002-I TIME-ALIGN®

SELF-POWERED

APPLICATIONS

Audio-Visual Installations
Restaurant Foreground Music Systems
Nightclub Installations
House of Worship Sound Reinforcement
Theatrical Sound Reinforcement

DESCRIPTION

The PTA2002-I is a self-powered Minima One™, full range, loudspeaker system. Designed for permanent installation, it offers both high fidelity and high efficiency. The Time-Aligned™ studio quality sound provides detail and clarity not found in other designs. The PTA2002-I has a rugged birch plywood enclosure finished with our beautiful utility black textured finish and a black steel grille. Optional flying attachment points allow for safe and convenient rigging.

The audio input incorporates an InGenius® balanced line receiver providing very high common mode rejection to eliminate noise often present in systems with less optimized grounding and wiring schemes. The internal Minima One™ amplifier incorporates a high efficiency low power consumption green design with advanced digital switching to automatically accept any line voltage from 88 to 270 volts. Low voltage contacts are provided for installations to remotely turn the amplifier on and off.



SPECIFICATIONS

System Type:

2-way vented 2 ft³

Enclosure:

18 mm 13-ply birch plywood

Finish:

Black Ro Tex™ True water born environmental finish

Grille:

16 Gauge black power coated perforated steel

Low Frequency Components:

SE-1280 12" Transducer, 2.5" Voice coil, 80 oz. Magnet

High Frequency Components:

E-700 1" Exit compression driver, 1.8" Titanium diaphragm, 15 oz. Magnet, Radial Waveguide

Input Connector:

XLR 1/4" combo with XLR loop through

Internal Amplification:

Minima One™

Input Impedance:

48K Ohms

Input CAL Sensitivity:

+4 dBu

Maximum Continuous Amplifier Power:

1350 W into 4 Ohms

High Pass Filter:

Switchable: -6 dB @ 8 Hz; @ 50 Hz; @ 95 Hz

Overload Protection:

Internal limiter

LED Indicators:

Green - On
Yellow - System limit
Red - System fault or sleep mode

Mains Voltage Requirements:

Auto sensing
Universal voltage range
88 Volts minimum to 270 Volts maximum

Mains Current Requirements:

2.3 Amps @ 120 Volts
1.2 Amps @ 240 Volts

Hardware:

Forged steel eye bolts

Fly Points Safe Working Load:

200 lbs Upper most rigging points

Crossover Type:

Passive Time-Align® equalizer type @ 2.5 kHz

Time Offset Between Driver:

< ± 25 Microseconds

Frequency Response:

70 Hz to 20 kHz ±3 dB

Low Frequency Limit:

55 Hz

Maximum Calculated Continuous Acoustic Output:

127 dB SPL @ 1m

Coverage Pattern:

80 degrees Horizontal (-6 dB)
60 degrees Vertical (-6 dB)
Rotatable horn

Polarity:

A positive asymmetrical signal applied to pin 2 will result in a positive asymmetrical acoustical pressure

Dimensions:

21" h x 17" w x 18" d
54 cm x 44 cm x 46 cm
Trapezoidal – 11 degree taper per side

Weight:

55 lbs
25 kg

Custom Finishes:

Optional custom finishes include white or unfinished ready to paint.

TIME-ALIGN®, TIME-ALIGNED™ and TIME-ALIGNMENT™ are trademarks of E.M. Long Associates.
MINIMA ONE™ is a trademark of Modular Sound Systems, Inc., BAG END® is a registered trademark of Bag End, Inc.

PTA2002-1 TIME-ALIGN®

ABOUT TIME-ALIGN® TECHNOLOGY

Time-Align® assures that the fundamental and overtones of a complex, transient, acoustical signal are presented to the listener in the same relationship as the electrical signal at the input terminals of the loudspeaker. The conventional loudspeaker spreads out the sound in time. When a rapid series of transients occur the results are blurring and lost detail. With Time-Align®, a transient is presented as a tight package of energy, with the same time relationships as the natural sound. This means that a rapid series of transients will be heard clearly.

True Time-Alignment™ requires much more than just physically lining up the loudspeaker components. It

requires consideration of the driver placement, driver delay and adjustment of the crossover delay parameters. This achieves the precise simultaneous acoustical arrival time of each driver throughout the crossover region.

The first Time-Aligned™ Loudspeaker was invented by EM Long Associates in 1976 utilizing the Time-Align® generator invented and built by Ronald Wickersham. In 1980 Bag End® incorporated Time-Align® technology into our full range loudspeaker systems. Along with state-of-the-art laboratory instruments, the proprietary Time-Align® generator is still in use today to verify the time domain performance of our loudspeaker systems. When comparing a genuine Bag End® Time-Aligned™ loudspeaker system to any other, our technology and design is easy to hear and appreciate. The dramatic clarity, realism, and overall pleasant sound of our Time-Aligned™ systems are well noted worldwide.

error to zero at the end of each cycle. On average, every 4 microseconds, the one cycle modulator transforms and amplifies the input signal into the ideal natural pulse width modulation. Switching at 250 kHz with the single cycle error correction insures extremely low distortion and high reliability. The power factor corrected AC power input, automatically and continuously adapts to any voltage between 88 and 270 volts. The Minima One™ is convenient and stable to operate on any power grid in the world.

ABOUT BAG END® LOUSPEAKERS

Bag End loudspeakers began in 1976 in a small shop by people dedicated to the pursuit of making high quality loudspeaker systems. Over the decades Bag End® has employed the very best construction techniques and innovative acoustical designs into their products. The ground breaking introductions of the Time-Align® and ELF™ Technologies into sound reinforcement and studio monitor loudspeakers in the 1980's was followed by Minima One™ self-powered systems and the highly unique E-Trap™, electronic bass trap. Over the decades, Bag End® has been a leader in providing uniquely good sounding products and extraordinary service to our customers world wide.

ABOUT MINIMA ONE™

The Minima One™ is both a high fidelity and a high efficiency amplifier. With efficiency well over 80%, the Minima One™ provides more power to the loudspeakers and creates less heat in the amplifier. In real world applications there is practically no heat emitted from the amplifier and thus it requires no cooling fan. Incorporating patented technology the comparison circuit of the Minima One™ corrects every single cycle to drive



DIMENSIONS

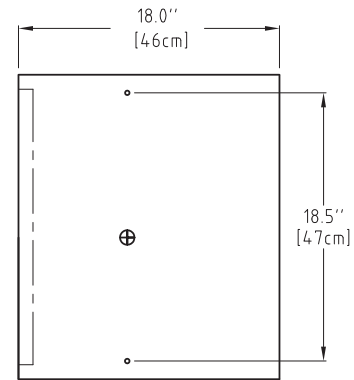
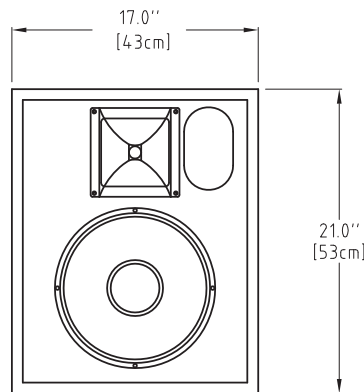
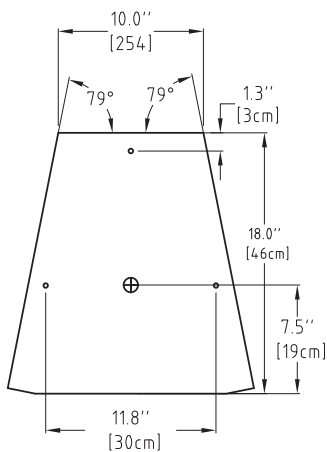

⊕ = Center of Gravity ○ = 5/16"- 18 Threaded Rigging Point



PTA2002-1 TIME-ALIGN®

SIDE VIEW

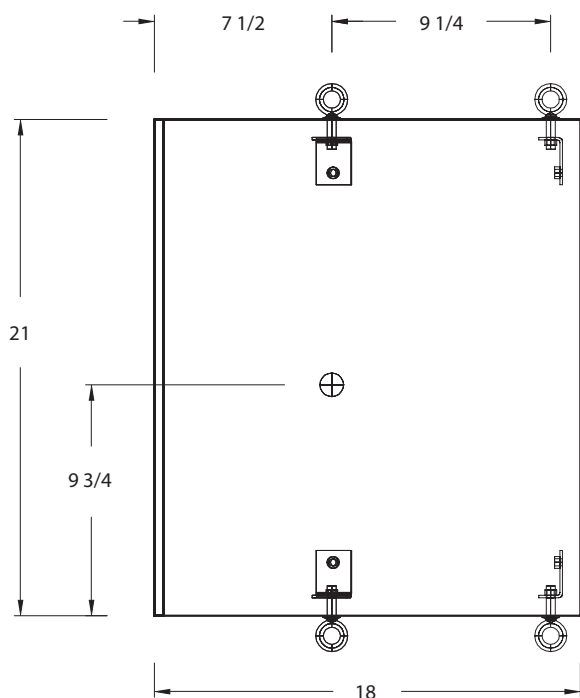

ISOMETRIC VIEW

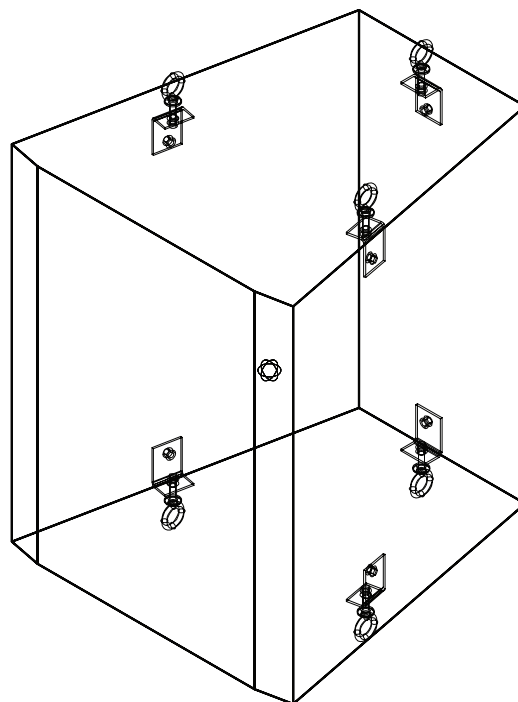

TOP VIEW

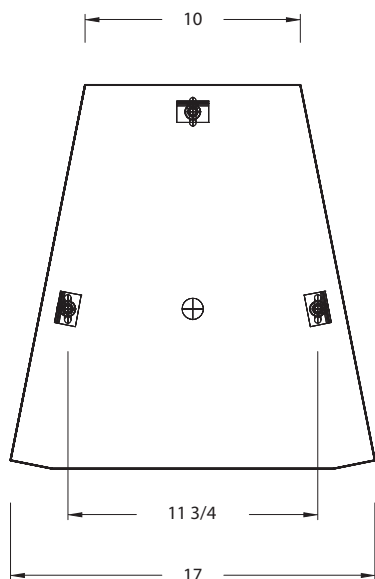

KEY

Center of Gravity: +

WARNINGS

Mounting and rigging loudspeakers requires experienced professionals. Improperly installed loudspeakers can result in property damage, personal injury, death and/or liability to the installing contractor.

FLYPOINTS

Includes flypoints as shown

plus 3 x 5/16"-18 forged shoulder eyebolts.