

S12E-R INFRASUB™

APPLICATIONS

Portable Sound Reinforcement Theatrical Sound Reinforcement
Portable DJ Systems Low Frequency Special Effects
Portable Musical Instrument Systems

DESCRIPTION

The S12E-R is an Infra™ subwoofer system designed to provide high fidelity extended low frequency audio reproduction from a relatively small enclosure. The S12E-R provides perfectly flat response down to 8 hertz when used in conjunction with the 8 hertz Integrator. Our external rack mount Infra-MXB Integrator is recommended to drive a line level Infra™ processed signal to the amplifiers driving one or more S12E-R systems. Designed for portable use, the S12E-R includes handles, durable grille and a pole mount adapter on a black Ro Tex™ finished enclosure.

SPECIFICATIONS

System Type:

Infrasub™ sealed chamber 1.4 ft³

Enclosure:

18 mm 13-ply birch plywood

Finish:

Black Ro Tex™ True water born environmental finish

Grille:

16 Gauge black power coated perforated steel

Low Frequency Components:

EL-12 12" Transducer, Infra™ cone,
2.5" Voice coil, 80 oz. Magnet

Input Connector:

Neutrik® speakON 1/4" combo jack

Crossover Type:

Requires external Infra™ Integrator

Sensitivity:

92 dB SPL @ 80 Hz (2.83 V @ 1m)

Frequency Response:

60 Hz to 250 Hz ±3 dB
8 Hz to 95 Hz ±3 dB with external Infra™
Integrator

Low Frequency Limit:

8 Hz

Maximum Calculated Continuous Acoustic Output:

Half Space @ 1 Meter
10 Hz - 81 dB SPL
20 Hz - 93 dB SPL
40 Hz - 105 dB SPL
80 Hz - 116 dB SPL

Power Handling:

200 W continuous (AES)
400 W program

Recommended Amplifier Power:

200 to 400 W at rated impedance

Rated Impedance:

8 Ohms

Polarity:

A positive asymmetrical signal applied to the + terminal will result in a positive asymmetrical acoustical pressure

Dimensions:

15" h x 18" w x 15" d
39 cm x 46 cm x 39 cm

Weight:

40 lbs
19 kg

Custom Finishes:

Optional custom finishes include white, unfinished ready to paint and outdoor weather treatment.

INFRA™, INFRASUB™ and DYNAMIC FILTER™ are trademarks of Modular Sound Systems, Inc.
BAG END® is a registered trademark of Bag End, Inc.



S12E-R INFRASUB™

ABOUT INFRASUB™ TECHNOLOGY

Almost all designs and specifications for subwoofer systems are fixated on the frequency response domain. However, the impression of power and quality of a loudspeaker is equally related to the time domain. The long wavelengths associated with low frequencies, make this particularly true with subwoofers. Likewise, the maximum SPL is not a very reliable way to judge the impact of a subwoofer. A poor time domain performer will not have the same impact or natural musically connected sound as a Time-Aligned™ Infra™ system. The reason that an Infra™ subwoofer sounds dramatically better is because of its superior time domain performance, as well as its extended low frequency response. The Infra™ subwoofer maintains the bass energy in a tight packet, aligned with the upper range signal, providing a greater body impact and a seamless musical connection with the main loudspeakers. Conventional subwoofer designs perform so poorly in the time domain because designers have used methods that sacrifice the phase response for more control over the frequency response (e.g.: steep low pass filter slopes, vented speaker enclosures, and narrow bandwidth systems). With the Infra™ technique, we do not degrade the phase response while extending the frequency response. While the Infra™ dual Integrator does function as the system crossover, it does so without using a conventional low pass filter. The Infra™ integrator applies an inverse electrical response to the acoustical response of the Infra™ loudspeaker in its

sealed enclosure. This provides both the upper frequency roll off and the extended frequency response while maintaining the hi sound quality often associated with a sealed box design. When comparing a genuine Bag End® Infra™ loudspeaker system to any other, our technology and design is easy to hear and appreciate. The dramatic clarity, realism, and overall pleasant sound of an Infra™ system is well noted throughout the world.

ABOUT DYNAMIC FILTER™

The Dynamic Filter™ is a complimentary technology to the Infra™ system taking unique advantage of the Infra™ design approach, to implement a reliable protection scheme that is transparent and inaudible to the listener. Systems using the external rack mount Infra-MXB processor require an appropriate threshold adjustment that sets the amplifiers power and sensitivity to the Infra™ loudspeakers in use. When a system is asked to do more than it is capable of, or if an accidentally large signal is presented the threshold of the Dynamic Filter™ is crossed and the system protects itself from the bottom up by reducing the lowest frequencies first. Since the most power and excursion is always required at the lowest frequency, reducing the level of the lowest frequencies first avoids an overload, while at the same time the system is able to reproduce the middle and upper bass and leave the upper crossover region unaffected. This is a very natural and inaudible method

to protect the system and unique to the Infra™ technology.

ABOUT OUR RO TEX™ FINISH

The durable Ro Tex™ finish is double layered on Bag End™ "R" series or Road cabinets. And single layered on installation or "I" cabinets. Ro Tex™ is a water born environmentally safe finish. It's uniquely strong and long lasting. As it solidifies it attaches and bonds to the wooden cabinet to make a super hard and durable permanent finish. Its light texture offers an attractive and rugged finished look

ABOUT BAG END® LOUSPEAKERS

Bag End loudspeakers began in 1976 in a small shop by people dedicated to the pursuit of making high quality loudspeaker systems. Over the decades Bag End® has employed the very best construction techniques and innovative acoustical designs into their products. The ground breaking introductions of the Time-Align® and ELF™ Technologies into sound reinforcement and studio monitor loudspeakers in the 1980's was followed by Minima One™ self-powered systems and the highly unique E-Trap™, electronic bass trap. Over the decades, Bag End® has been a leader in providing uniquely good sounding products and extraordinary service to our customers world wide.

DIMENSIONS

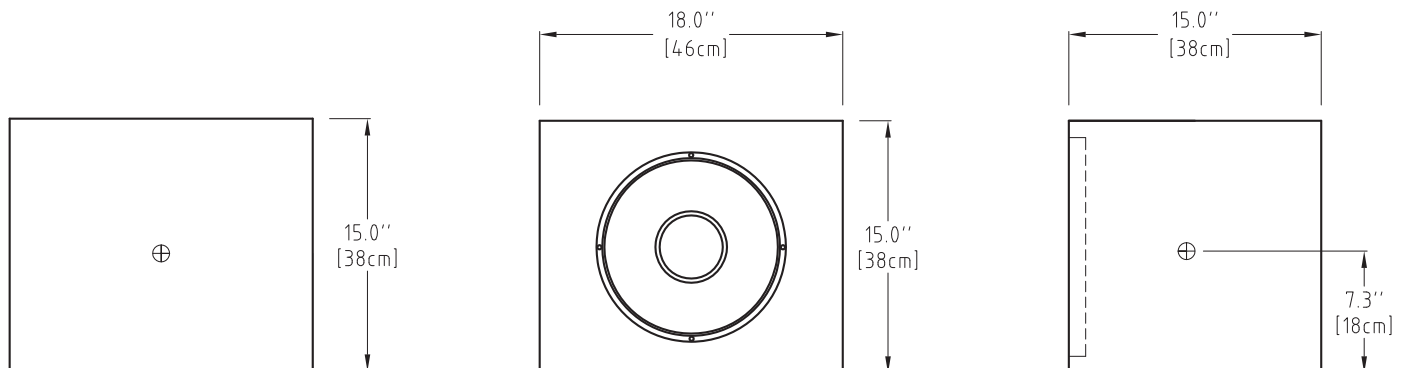

⊕ = Center of Gravity