

# S18E-R INFRASUB™

## APPLICATIONS

Portable Sound Reinforcement      Low Frequency Drum Monitor  
Portable DJ Systems                  Low Frequency Special Effects  
Theatrical Sound Reinforcement

## DESCRIPTION

The S18E-R is a high output Infra™ subwoofer system designed to provide high fidelity extended low frequency audio reproduction from a relatively small enclosure. The S18E-R provides perfectly flat response down to 8 hertz when used in conjunction with the 8 hertz Integrator. Our external rack mount Infra-MXB Integrator is recommended to drive a line level Infra™ processed signal to the amplifiers driving one or more S18E-R systems. Designed for portable use, the S18E-R offers a black Ro Tex™ finish and a black coated steel grille.



## SPECIFICATIONS

### System Type:

Infrasub™ sealed chamber 3 ft<sup>3</sup>

### Enclosure:

18 mm 13-ply birch plywood

### Finish:

Black Ro Tex™ True water born environmental finish

### Grille:

16 Gauge black power coated perforated steel

### Low Frequency Components:

EL-18A 18" Transducer, Infra™ cone,  
3" Voice coil, 120 oz. Magnet

### Input Connector:

Neutrik® speakON 1/4" combo jack

### Hardware:

2 - Recessed handles  
35 mm Pole mount adapter  
4 - Machined aluminum speaker  
mounting clamps

### Crossover Type:

Requires external Infra™ Integrator

### Sensitivity:

96 dB SPL @ 80 Hz (2.83 V @ 1m)

### Frequency Response:

60 Hz to 250 Hz ±3 dB  
8 Hz to 95 Hz ±3 dB with external Infra™  
Integrator

### Low Frequency Limit:

8 Hz

### Maximum Calculated Continuous Acoustic Output:

Half Space @ 1 Meter  
10 Hz - 89 dB SPL  
20 Hz - 101 dB SPL  
40 Hz - 113 dB SPL  
80 Hz - 124 dB SPL

### Power Handling:

400 W continuous (AES)  
800 W program

### Recommended Amplifier Power:

400 to 800 W at rated impedance

### Rated Impedance:

8 Ohms

### Polarity:

A positive asymmetrical signal applied to the + terminal will result in a positive asymmetrical acoustical pressure

### Dimensions:

21" h x 22" w x 18" d  
54 cm x 56 cm x 46 cm

### Weight:

64 lbs  
29 kg

### Custom Finishes:

Optional custom finishes include white, unfinished ready to paint and outdoor weather treatment.

INFRA™, INFRASUB™ and DYNAMIC FILTER™ are trademarks of Modular Sound Systems, Inc.  
BAG END® is a registered trademark of Bag End, Inc.

# S18E-R INFRASUB™

## ABOUT INFRASUB™ TECHNOLOGY

Almost all designs and specifications for subwoofer systems are fixated on the frequency response domain. However, the impression of power and quality of a loudspeaker is equally related to the time domain. The long wavelengths associated with low frequencies, make this particularly true with subwoofers. Likewise, the maximum SPL is not a very reliable way to judge the impact of a subwoofer. A poor time domain performer will not have the same impact or natural musically connected sound as a Time-Aligned™ Infra™ system. The reason that an Infra™ subwoofer sounds dramatically better is because of its superior time domain performance, as well as its extended low frequency response. The Infra™ subwoofer maintains the bass energy in a tight packet, aligned with the upper range signal, providing a greater body impact and a seamless musical connection with the main loudspeakers. Conventional subwoofer designs perform so poorly in the time domain because designers have used methods that sacrifice the phase response for more control over the frequency response (e.g.: steep low pass filter slopes, vented speaker enclosures, and narrow bandwidth systems). With the Infra™ technique, we do not degrade the phase response while extending the frequency response. While the Infra™ dual Integrator does function as the system crossover, it does so without using a conventional low pass filter. The Infra™

integrator applies an inverse electrical response to the acoustical response of the Infra™ loudspeaker in its sealed enclosure. This provides both the upper frequency roll off and the extended frequency response while maintaining the hi sound quality often associated with a sealed box design. When comparing a genuine Bag End® Infra™ loudspeaker system to any other, our technology and design is easy to hear and appreciate. The dramatic clarity, realism, and overall pleasant sound of an Infra™ system is well noted throughout the world.

## ABOUT DYNAMIC FILTER™

The Dynamic Filter™ is a complimentary technology to the Infra™ system, taking unique advantage of the Infra™ design approach, to implement a reliable protection scheme that is transparent and inaudible to the listener. In self processed systems the Dynamic Filter™ threshold is internally preset. Systems using the external rack mount Infra-MXB processor require an appropriate threshold adjustment that sets the amplifiers power and sensitivity to the Infra™ loudspeakers in use. With Infra™ processing we extend an acoustically flat frequency response, well below the audible range, as low as 8 hertz, using amplifier power and driver excursion. As you go down in frequency this requires significant power and excursion to maintain the acoustically flat response. Typical musical content does

not contain equal energy per octave, especially in the lowermost range. As a practical matter music program does not require the extreme amplifier power or excursion that a simple calculation would indicate. Exceptions occur when a system is asked to do more than it is capable of, or if an accidentally large signal is presented. When this occurs the threshold of the Dynamic Filter™ is crossed and the system protects itself from the bottom up by reducing the lowest frequencies first. Since the most power and excursion is always required at the lowest frequency, reducing the level of the lowest frequencies first avoids an overload, while at the same time the system is able to reproduce the middle and upper bass and leave the upper crossover region unaffected. This is a very natural and inaudible method to protect the system and unique to the Infra™ technology.

## ABOUT OUR RO TEX™ FINISH

The durable Ro Tex™ finish is double layered on Bag End™ "R" series or Road cabinets. And single layered on installation or "I" cabinets. Ro Tex™ is a water born environmentally safe finish. It's uniquely strong and long lasting. As it solidifies it attaches and bonds to the wooden cabinet to make a super hard and durable permanent finish. Its light texture offers an attractive and rugged finished look

## DIMENSIONS

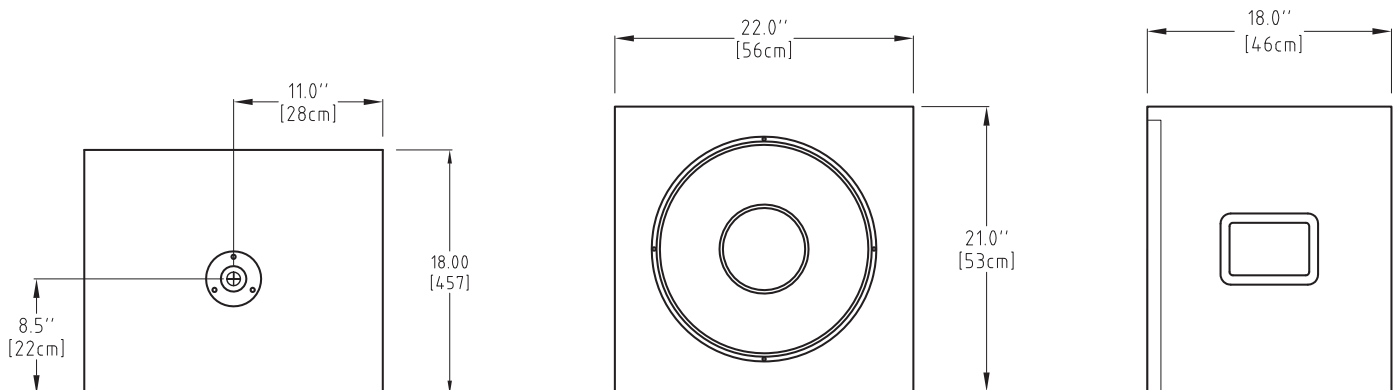

⊕ = Center of Gravity