

TA1202-B TIME-ALIGN®

APPLICATIONS

Audio-Visual Installations	House of Worship
Restaurant Foreground Music Systems	Theatrical Sound Reinforcement
Nightclub Installations	Electronic Keyboards

DESCRIPTION

The TA1202-R produces high definition high impact sound over its controlled coverage angle allowing precise effective audience coverage in a variety of venues. This point source loudspeaker, engineered for seamless short and mid throw performance is well known for exceptional fidelity and its surprisingly high output capability. It excels in speech projection and live performance PA systems as well as high level music playback systems.

The rotatable 80 degree (h) by 60 degree (v) coverage pattern offers optimal coverage options for horizontal or vertical applications

The TA1202-R includes an internal passive Time-Align crossover and optimal venting provides a surprisingly powerful bass output. The TA1202-R is a rectangular cabinet making it store and transport efficiently. The internal cabinet volume is also maximized for the cabinets footprint for greater bass response. With its hi fidelity, convenient size and hi output its perfect for many stand alone applications. Adding Bag End subwoofers will expand its capabilities to include larger venues.

Constructed from 18mm Baltic Birch plywood the TA1202-R includes a durable black Ro Tex finish, durable steel grille, Integral handles, NL-4 input combo jack and an internal stand adapter making it a perfect choice for a multitude of applications.



SPECIFICATIONS

System Type:

2-way vented 1.1 ft³

Enclosure:

18mm 13-ply birch plywood

Finish:

Oiled Birch

Grille:

16 Gauge black power coated perforated steel

Low Frequency Components:

SE-1280 12" Transducer, 2.5" Voice coil, 80 oz. Magnet

High Frequency Components:

E-700 1" Exit compression driver, 1.8" Titanium diaphragm, 15 oz. Magnet, Radial Waveguide

Input Connector:

Neutrik® speakON 1/4" combo jack wired to Pin 1
Optional input plate available for Pin 2 wiring

Hardware:

Recessed handle
35 mm Stand adapter

Crossover Type:

Passive Time-Align® equalizer filter @ 2.5 kHz

Time Offset Between Driver:

< ± 25 Microseconds

Sensitivity:

101 dB SPL (2.83 V @ 1m)

Frequency Response:

75 Hz to 20 kHz ±3 dB

Low Frequency Limit:

65 Hz

Maximum Calculated Continuous Acoustic Output:

127 dB SPL @ 1m

Power Handling:

300 W continuous (IEC)
600 W program

Recommended Amplifier Power:

300 to 600 W at rated impedance

Rated Impedance:

8 Ohms

Coverage Pattern:

80 degrees Horizontal (-6 dB)
60 degrees Vertical (-6 dB)
Rotatable horn

Recommended High Pass Filter:

60 Hz

Polarity:

A positive asymmetrical signal applied to the + terminal will result in a positive asymmetrical acoustical pressure

Dimensions:

21" h x 14" w x 11.5" d
54 cm x 36 cm x 30 cm

Weight:

43 lbs
20 kg

Custom Finishes:

Optional custom finishes include white or unfinished ready to paint.

TIME-ALIGN®, TIME-ALIGNED™ and TIME-ALIGNMENT™ are trademarks of E.M. Long Associates.
BAG END® is a registered trademark of Bag End, Inc.



TA1202-B TIME-ALIGN®

ABOUT TIME-ALIGN® TECHNOLOGY

Time-Align® assures that the fundamental and overtones of a complex, transient, acoustical signal are presented to the listener in the same relationship as the electrical signal at the input terminals of the loudspeaker. The conventional loudspeaker spreads out the sound in time. When a rapid series of transients occur the results are blurring and lost detail. With Time-Align®, a transient is presented as a tight package of energy, with the same time relationships as the natural sound. This means that a rapid series of transients will be heard clearly.



True Time-Alignment™ requires much more than just physically lining up the loudspeaker components. It requires consideration of the driver placement, driver delay and adjustment of the crossover delay parameters. This achieves the precise simultaneous acoustical arrival time of each driver throughout the crossover region.

The first Time-Aligned™ Loudspeaker was invented by EM Long Associates in 1976 utilizing the Time-Align® generator invented and built by Ronald Wickersham. In 1980 Bag End® incorporated Time-Align® technology into our full range loudspeaker systems. Along with state-of-the-art laboratory instruments, the proprietary Time-Align® generator is still in use today to verify the time domain performance of our loudspeaker systems. When comparing a genuine Bag End® Time-Aligned™ loudspeaker system to any other, our technology and design is easy to hear and appreciate. The dramatic clarity, realism, and overall pleasant sound of our Time-Aligned™ systems are well noted worldwide.

ABOUT NATURAL OILED BIRCH CABINETS

Bag End® Natural Oiled Birch enclosures were the original cabinets we made starting in 1975. In the 1970's we made all our cabinets from the highest grade clear face Finland Birch plywood with a hand rubbed oil finish. At first look these cabinets may seem to be fragile and

too nice looking for use for portable systems, but the durability and longevity is now well proven. Many Oiled Birch cabinets are still in use 30 years later and perform as well today as the day they were made. With use and travel the finish will nick and ding and over time and the cabinet acquires a patina like finish. This is especially enhanced if you occasionally re-oil it. Today most of our production is still made with Finland Birch plywood and finished with durable black Ro Tex™. The classic clear face Finland Birch plywood with the hand rubbed oiled finish is available on several standard models and many other model can be custom ordered in this finish.

ABOUT BAG END® LOUSPEAKERS

Bag End loudspeakers began in 1976 in a small shop by people dedicated to the pursuit of making high quality loudspeaker systems. Over the decades Bag End® has employed the very best construction techniques and innovative acoustical designs into their products. The ground breaking introductions of the Time-Align® and ELF™ Technologies into sound reinforcement and studio monitor loudspeakers in the 1980's was followed by Minima One™ self-powered systems and the highly unique E-Trap™, electronic bass trap. Over the decades, Bag End® has been a leader in providing uniquely good sounding products and extraordinary service to our customers world wide.

DIMENSIONS

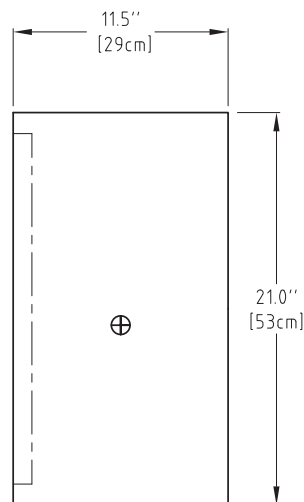
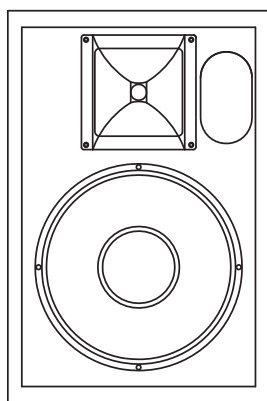
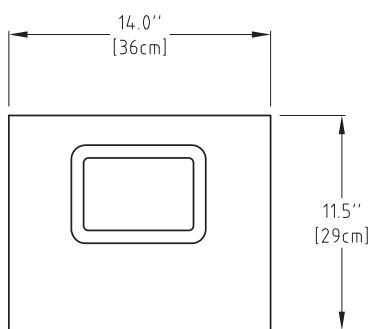

⊕ = Center of Gravity

○ = 5/16"- 18 Threaded Rigging Point