

IPS10E-SHV2 INFRASUB™

APPLICATIONS

Installed Special Effects	Mastering Facility
Museum Interactive Displays	Home Theater
Film and Video Post Production	Foreground Music Systems
Recording Studio	

DESCRIPTION

The IPS10E-SHV2 is a self-powered and internally Infra™ processed single 10" bass system designed for extended life continuous duty permanent installations. The internal Minima 3™ amplifier and Infra™ processing provides for convenient implementation and wiring. The internal Infra™ integrator, amplifier and loudspeaker process the full range signal into a flat response low frequency acoustic output. The Dynamic Filter™ protection threshold is internally preset to eliminate distortion or accidental overload. This insures the maximum output and robust system protection with virtually no audible effect.

The audio input incorporates an InGenius® balanced line receiver, providing very high common mode rejection, to eliminate noise often present in systems with less optimized grounding and wiring schemes. The internal Minima 3™ amplifier incorporates a high efficiency low power consumption green design with advanced digital switching to automatically switch and accept line voltage from 100 to 240 volts.

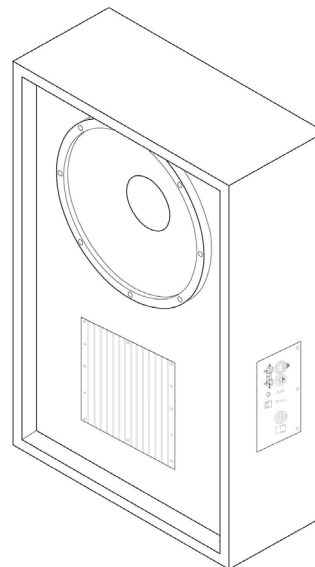

SPECIFICATIONS

System Type:

Infrasub™ sealed chamber 0.75 ft³

Enclosure:

18 mm and 12 mm birch plywood

Finish:

Black Ro Tex™ true water born environmental finish

Grille:

Not included
Optional 16 Gauge black powder coated perforated steel or black nylon cloth over wood frame

Low Frequency Components:

EL-10 10" Infra™ extended low frequency transducer cone, 2.5" Voice coil, 68 oz Magnet

Input Connector:

2 XLR summing inputs w/ one XLR male loop through, mounted on 20.5" side

Internal Amplification:

Minima 3™

Input Impedance:

10K ohms

Input CAL Sensitivity:

+4 dBu

Maximum Continuous Amplifier Power:

300 W

LED Indicators:

Green - On
Yellow - Dynamic Filter™ threshold

Mains Voltage Requirements:

Auto sensing
100 / 120 / 240 V

Mains Current Requirements:

1.6 A @ 120 V
0.8 A @ 240 V

Hardware:

Optional fly points available

Fly Points Safe Working Load:

Optional F4 rigging points
200 lbs Upper most points

Crossover Type:

Internal Infra™ integrator inside

Frequency Response:

8 Hz to 95 Hz ±3 dB

Maximum Calculated Continuous Acoustic Output:

Half Space @ 1 Meter
10 Hz - 79 dB SPL
20 Hz - 91 dB SPL
40 Hz - 103 dB SPL
80 Hz - 113 dB SPL

Polarity:

A positive asymmetrical signal applied to pin 2 will result in a positive asymmetrical acoustical pressure

Dimensions:

20.5" h x 16" w x 7" d

Weight:

42 lbs

Other Options:

REMCON-2 Optional remote Dynamic Filter™ threshold indicator

Custom Finishes:

Optional custom finishes include white or unfinished ready to paint.

INFRA™, INFRASUB™, MINIMA 3™ and DYNAMIC FILTER™ are trademarks of Modular Sound Systems, Inc.
BAG END® is a registered trademark of Bag End, Inc.

IPS10E-SHV2 INFRASUB™

ABOUT INFRASUB™ TECHNOLOGY

Almost all designs and specifications for subwoofer systems are fixated on the frequency response domain. However, the impression of power and quality of a loudspeaker is equally related to the time domain. The long wavelengths associated with low frequencies make this particularly true with subwoofers. Likewise, the maximum SPL is not a very reliable way to judge the impact of a subwoofer. A poor time domain performer will not have the same impact or natural musically connected sound as a Time-Aligned™ Infra™ system. The reason that an Infra™ subwoofer sounds dramatically better is because of their superior time domain performance, as well as their extended low frequency response. The Infra™ subwoofer maintains the bass energy in a tight packet, aligned with the upper range signal, providing a greater body impact and a seamless musical connection with the main loudspeakers. Conventional subwoofer designs perform poorly in the time domain because designers have used methods that sacrifice the phase response for more control over the frequency response (e.g.: steep low pass filter slopes, vented speaker enclosures, and narrow bandwidth systems). With the Infra™ technique, we do not degrade the phase response while extending the frequency response.

While the Infra™ dual Integrator does function as the system crossover, it does so without using a conventional low pass filter. The Infra™ integrator applies an inverse electrical response to the acoustical response of the Infra™ loudspeaker in its sealed enclosure. This provides the extended frequency response while maintaining the hi fidelity sound quality associated with a sealed box design. This design approach requires the most amplifier power to be used at the lowest frequency, thus we implement the Dynamic Filter™ technology to protect the system from the bottom up, affecting the lowest frequency first and leaving the middle and upper bass unaffected. The Dynamic Filter™ is a complimentary technology to the Infra™ system taking unique advantage of the Infra™ design approach, to implement a reliable protection scheme that is transparent and inaudible to the listener. When comparing a genuine Bag End® Infra™ loudspeaker system to any other, our technology and design is easy to hear and appreciate. The dramatic clarity, realism, and overall pleasant sound of an Infra™ system is well noted throughout the world.

ABOUT MINIMA 3™ SELF POWERED

The Minima 3™ amplifier is both a high fidelity and a high efficiency amplifier. With efficiency well over 80%, it provides more power to the loudspeakers, and creates

less heat in the amplifier. In real world applications there is practically no heat emitted from the amplifier and thus it requires no cooling fan. The universal AC power input automatically accepts 100, 120 or 240 volts allowing it to operate anywhere in the world.

ABOUT BAG END® LOUDSPEAKERS

Bag End loudspeakers began in 1976 in a small shop by people dedicated to the pursuit of making high quality loudspeaker systems. Over the decades Bag End® has employed the very best construction techniques and innovative acoustical designs into their products. The ground breaking introductions of the Time-Align® and ELF™ Technologies into sound reinforcement and studio monitor loudspeakers in the 1980's was followed by Minima One™ self-powered systems and the highly unique E-Trap™, electronic bass trap. Over the decades, Bag End® has been a leader in providing uniquely good sounding products and extraordinary service to our customers world wide.

DIMENSIONS

