

D10E-I INFRASUB™

APPLICATIONS

Laboratory Reference System	House of Worship
Recording Studio and Mastering	Theatrical Sound Reinforcement
Post Production and Screening Room	Installed Audio-Visual Systems
Restaurant Foreground Music Systems	Nightclub Installation

DESCRIPTION

The D10E-I is an Infra™ subwoofer system designed to provide high fidelity extended low frequency audio reproduction from a relatively small enclosure. The D10E-I provides perfectly flat response down to 8 hertz when used in conjunction with the 8 hertz Integrator. Our external rack mount Infra-MXB Integrator is recommended to drive a line level Infra™ processed signal to the amplifiers driving one or more D10E-I systems. Designed for permanent installation, the D10E-I offers a black textured finish, a black coated steel grille and optional fly points.



SPECIFICATIONS

System Type:

Infrasub™ sealed chamber 1.4 ft³

Enclosure:

18 mm 13-ply birch plywood

Finish:

Black Ro Tex™ True water born environmental finish

Grille:

16 Gauge black power coated perforated steel

Low Frequency Components:

2 - EL-10 10" Transducers, Infra™ cone, 2.5" Voice coil, 68 oz. Magnet

Input Connector:

Cinch 142 screw terminal barrier strip

Hardware:

Optional F2 Fly points available

Fly Points Safe Working Load:

200 lbs.

Crossover Type:

Requires external Infra™ Integrator

Sensitivity:

92 dB SPL @ 80 Hz (2.83 V @ 1m)

Frequency Response:

60 Hz to 250 Hz ±3 dB
8 Hz to 95 Hz ±3 dB with external Infra™ Integrator

Low Frequency Limit:

8 Hz

Maximum Calculated Continuous Acoustic Output:

Half Space @ 1 Meter
10 Hz - 84 dB SPL
20 Hz - 96 dB SPL
40 Hz - 108 dB SPL
80 Hz - 119 dB SPL

Power Handling:

400 W continuous (AES)
800 W program

Recommended Amplifier Power:

400 to 800 W at rated impedance

Rated Impedance:

4 Ohms

Polarity:

A positive asymmetrical signal applied to the + terminal will result in a positive asymmetrical acoustical pressure

Dimensions:

13" h x 22.5" w x 13" d
33 cm x 57 cm x 33 cm

Weight:

44 lbs
20 kg

Custom Finishes:

Optional custom finishes include white, unfinished ready to paint and outdoor weather treatment.

INFRA™, INFRASUB™ and DYNAMIC FILTER™ are trademarks of Modular Sound Systems, Inc.
BAG END® is a registered trademark of Bag End, Inc.

D10E-I INFRASUB™

ABOUT INFRASUB™ TECHNOLOGY

Almost all designs and specifications for subwoofer systems are fixated on the frequency response domain. However, the impression of power and quality of a loudspeaker is equally related to the time domain. The long wavelengths associated with low frequencies make this particularly true with subwoofers. Likewise, the maximum SPL is not a very reliable way to judge the impact of a subwoofer. A poor time domain performer will not have the same impact or natural musically connected sound as a Time-Aligned™ Infra™ system. The reason that an Infra™ subwoofer sounds dramatically better is because of their superior time domain performance, as well as their extended low frequency response. The Infra™ subwoofer maintains the bass energy in a tight packet, aligned with the upper range signal, providing a greater body impact and a seamless musical connection with the main loudspeakers. Conventional subwoofer designs perform so poorly in the time domain because designers have used methods that sacrifice the phase response for more control over the frequency response (e.g.: steep low pass filter slopes, vented speaker enclosures, and narrow bandwidth systems). With the Infra™ technique, we do not degrade the phase response while extending the frequency response.

While the Infra™ dual Integrator does function as the system crossover, it does so without using a

conventional low pass filter. The Infra™ integrator applies an inverse electrical response to the acoustical response of the Infra™ loudspeaker in its sealed enclosure. This provides the extended frequency response while maintaining the hi sound quality often associated with a sealed box design. This design approach requires the most amplifier power to be used at the lowest frequency, thus we implement the Dynamic Filter™ technology to protect the system from the bottom up, affecting the lowest frequency first and leaving the middle and upper bass unaffected. The Dynamic Filter™ is a complimentary technology to the Infra™ system taking unique advantage of the Infra™ design approach, to implement a reliable protection scheme that is transparent and inaudible to the listener. When comparing a genuine Bag End® Infra™ loudspeaker system to any other, our technology and design is easy to hear and appreciate. The dramatic clarity, realism, and overall pleasant sound of an Infra™ system is well noted throughout the world.

ABOUT DYNAMIC FILTER™

The Dynamic Filter™ is a complimentary technology to the Infra™ system, taking unique advantage of the Infra™ design approach, to implement a reliable protection scheme that is transparent and inaudible to the listener. In self processed systems the Dynamic Filter™ threshold is internally preset. Systems using the

external rack mount Infra-MXB processor require an appropriate threshold adjustment that sets the amplifiers power and sensitivity to the Infra™ loudspeakers in use. With Infra™ processing we extend an acoustically flat frequency response, well below the audible range, as low as 8 hertz, using amplifier power and driver excursion. As you go down in frequency this requires significant power and excursion to maintain the acoustically flat response. Typical musical content does not contain equal energy per octave, especially in the lowermost range. As a practical matter music program does not require the extreme amplifier power or excursion that a simple calculation would indicate. Exceptions occur when a system is asked to do more than it is capable of, or if an accidentally large signal is presented. When this occurs the threshold of the Dynamic Filter™ is crossed and the system protects itself from the bottom up by reducing the lowest frequencies first. Since the most power and excursion is always required at the lowest frequency, reducing the level of the lowest frequencies first avoids an overload, while at the same time the system is able to reproduce the middle and upper bass and leave the upper crossover region unaffected. This is a very natural and inaudible method to protect the system and unique to the Infra™ technology.

DIMENSIONS

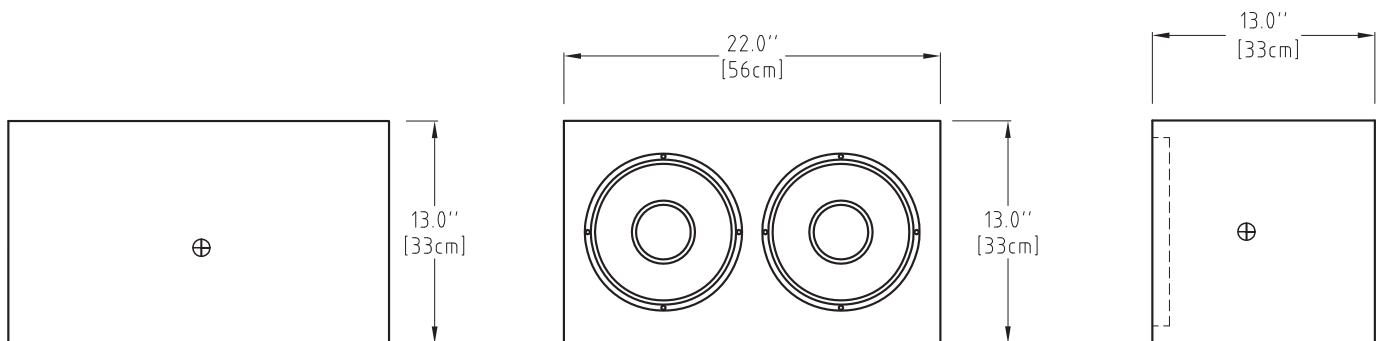

⊕ = Center of Gravity

D10E-I INFRASUB™

SIDE VIEW

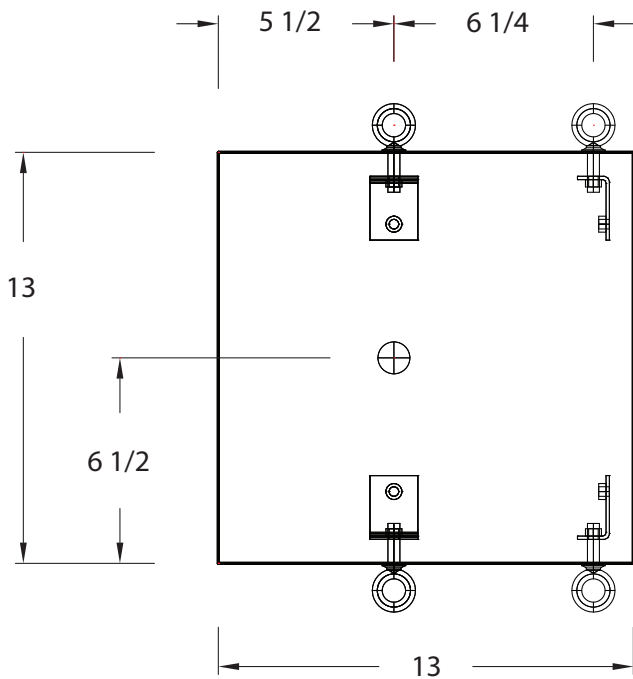

ISOMETRIC VIEW

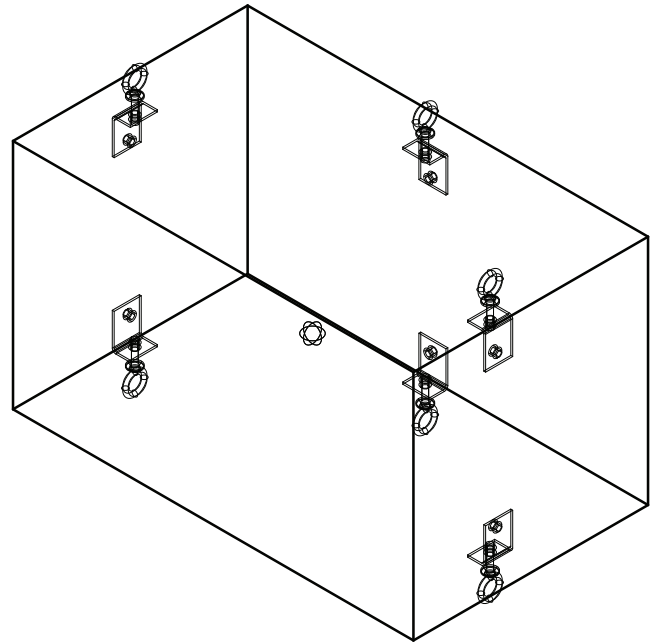

TOP VIEW

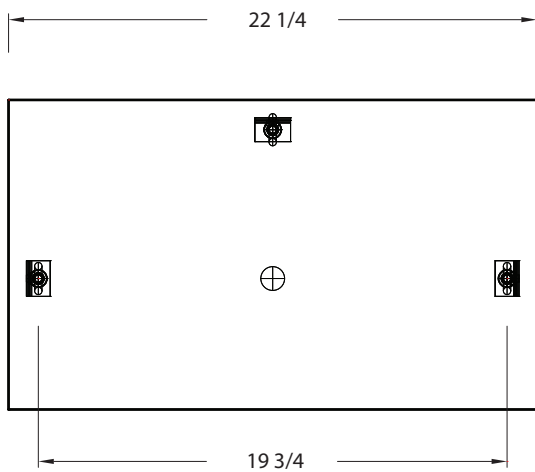

KEY

Center of Gravity: +

WARNINGS

Mounting and rigging loudspeakers requires experienced professionals. Improperly installed loudspeakers can result in property damage, personal injury, death and/or liability to the installing contractor.

FLYPOINTS

This optional hardware packet includes flypoints as shown plus 3 x 5/16" - 18 forged shoulder eyebolts