



APPLICATIONS:

Live Performance
Karaoke
Audio Visual Presentations
PA Systems
Foreground Music Systems
House of Worship

BE-D12 The BE-D12 is a high power, high efficiency subwoofer system featuring dual 12" transducers with 4" voice coil and 220mm magnet designed to provide high output sub bass response in a compact bass reflex enclosure, ideally for low frequency augmentation in conjunction with two or three-way full range loudspeaker system for fix or mobile installation. The BE-D12 is made of high quality durable MDF and plywood coated with black paint and a rugged steel grille. Included are pole mount socket for satellite speaker mounting and NL4 input connectors. System requires using with electronic crossover.

SYSTEM COMPONENTS

Enclosure:
18 mm MDF plus plywood

Low Frequency Transducers:
2 x 12"

Input Connectors:
NL4 Speakon 1+ 1-

Grille:
Black coated perforated steel

Pole Mount Socket:
Included (Top & Side)

ACOUSTIC AND ELECTRICAL

System Type:
Subwoofer

Impedance:
4 Ω

Frequency Response:
40 Hz to 400 Hz \pm 3 dB

Sensitivity:
105 dB SPL(1W/1M)

Power Handling:
1000 W RMS

PHYSICAL

Finish:
Black

Dimensions:
57 cm x 40 cm x 75 cm

Weight:
48 kg

Shipping Dimensions:
65 cm x 48 cm x 84 cm

Shipping Weight:
54 kg

BAG END Loudspeakers
22N272 Pepper Road
Lake Barrington, Illinois
60010 USA
Voice 847 382 4550
Fax 847 382 4551
www.bagend.com





BE-D12

TOP

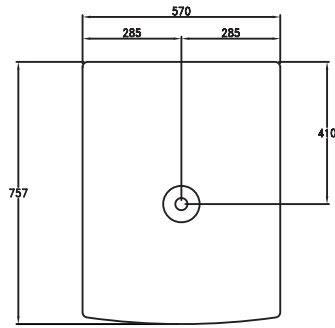

BOTTOM

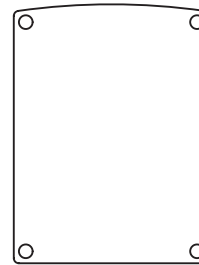

LEFT SIDE

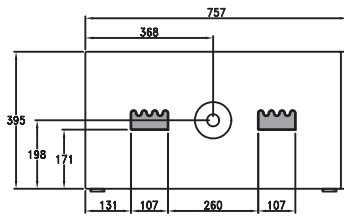

FRONT

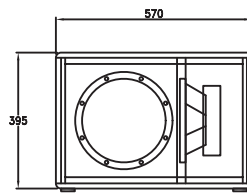

RIGHT SIDE

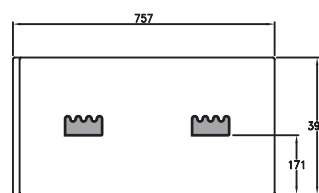

BACK

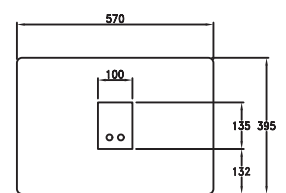

SYSTEM SCHEMATIC

