

TA80T-IY TIME-ALIGN®

APPLICATIONS

Audio-Visual Installations	House of Worship Installations
Front Fill for Large Systems	Restaurant Foreground Music Systems
Auditorium Under Balcony Fill	Fitness Centers
Nightclub Installations	Surround Sound Systems

DESCRIPTION

The TA80T-IY produces high definition high impact sound over its wide angle, making audience coverage easy and effective in a variety of venues. The ½ trapezoidal shape allows for close mounting to ceilings with a downward angle while maintaining the maximum cabinet volume for excellent upper bass response. A compact loudspeaker, engineered for exceptional mid field and near field performance, it is well known for exceptional fidelity and its surprisingly high output capability.

Useful for foreground and background music applications, it also excels for speech projection and small PA systems. With its fidelity, size and output it is perfect for multi channel 5.1 presentation systems. In larger audio systems the TA80T-IY is highly effective as a fill, delay or under balcony speaker. The addition of a Bag End subwoofer will expand its capabilities for more demanding applications.

The conical high frequency waveguide produces a uniform horizontal and vertical coverage pattern and the included steel mounting yoke U-Bracket enables vertical or horizontal mounting for easy installation and aiming.



SPECIFICATIONS

System Type:

2-way vented 0.65 ft³

Enclosure:

¾" MDF

Finish:

Black Ro Tex™ true water born environmental finish

Grille:

18 Gauge black powder coated perforated steel

Low Frequency Components:

E-8A 8" Driver, 2.5" Voice coil, 34 oz Magnet

High Frequency Components:

E-100 1" Exit compression driver,
1" Mylar diaphragm, Ceramic magnet,
Hybrid conical waveguide

Input Connector:

Cinch 142 screw terminal barrier strip

Internal Amplification:

Optional self powered

Hardware:

Steel yoke model TA8S

Crossover Type:

Passive Time-Align® equalizer type at 2.8 kHz

Time Offset Between Driver:

< ± 25 Microseconds

Frequency Response:

110 Hz to 20 kHz ±3 dB

Low Frequency Limit:

85 Hz

Maximum Calculated Continuous Acoustic Output:

120 dB SPL @ 1 m

Power Handling:

250 W continuous (IEC)
500 W program

Recommended Amplifier Power:

250 to 500 W at rated impedance

Rated Impedance:

8 ohms

Coverage Pattern:

90 degrees horizontal (-6 dB)
90 degrees vertical (-6 dB)

Recommended High Pass Filter:

85 Hz

Polarity:

A positive asymmetrical signal applied to the + terminal will result in a positive asymmetrical acoustical pressure

Dimensions:

14" h x 10" w x 11.5" d
35 cm x 25 cm x 29 cm

Weight:

32 lbs
14 kg

Custom Finishes:

Optional custom finishes include white or unfinished ready to paint.

70/100/140 Volt Operation:

Optional 60 W taped internal transformer

TIME-ALIGN®, TIME-ALIGNED™ and TIME-ALIGNMENT™ are trademarks of E.M. Long Associates.
BAG END® is a registered trademark of Bag End, Inc.

TA80T-1Y TIME-ALIGN®

ABOUT TIME-ALIGN® TECHNOLOGY

Time-Align® assures that the fundamental and overtones of a complex, transient, acoustical signal are presented to the listener in the same relationship as the electrical signal at the input terminals of the loudspeaker. The conventional loudspeaker spreads out the sound in time. When a rapid series of transients occur the results are blurring and lost detail. With Time-Align®, a transient is presented as a tight package of energy, with the same time relationships as the natural sound. This means that a rapid series of transients will be heard clearly.

True Time-Alignment™ requires much more than just physically lining up the loudspeaker components. It requires consideration of the driver placement, driver delay and adjustment of the crossover delay parameters. This achieves the precise simultaneous acoustical arrival time of each driver throughout the crossover region.

The first Time-Aligned™ Loudspeaker was invented by EM Long Associates in 1976 utilizing the Time-Align® generator invented and built by Ronald Wickersham. In 1980 Bag End® incorporated Time-Align® technology into our full range loudspeaker systems. Along with state-of-the-art laboratory instruments, the proprietary Time-Align® generator is still in use today to verify the time domain performance of our loudspeaker systems. When comparing a genuine Bag End® Time-Aligned™ loudspeaker system to any other, our technology and design is easy to hear and appreciate. The dramatic clarity, realism, and overall pleasant sound of our Time-Aligned™ systems are well noted worldwide.

to make a super hard permanent finish. It is lightly textured offering both an attractive and rugged finish.

ABOUT BAG END® LOUSPEAKERS

Bag End loudspeakers began in 1976 in a small shop by people dedicated to the pursuit of making high quality loudspeaker systems. Over the decades Bag End® has employed the very best construction techniques and innovative acoustical designs into their products. The ground breaking introductions of the Time-Align® and ELF™ Technologies into sound reinforcement and studio monitor loudspeakers in the 1980's was followed by Minima One™ self-powered systems and the highly unique E-Trap™, electronic bass trap. Over the decades, Bag End® has been a leader in providing uniquely good sounding products and extraordinary service to our customers world wide.

ABOUT OUR RO TEX™ FINISH

The durable Ro Tex™ finish is found on Bag End™ "R" series or Road cabinets. Ro Tex™ is a water base, environmentally safe finish that is made in Europe and is uniquely strong and long lasting. As it solidifies and attaches to the wooden cabinet it bonds with the wood



DIMENSIONS

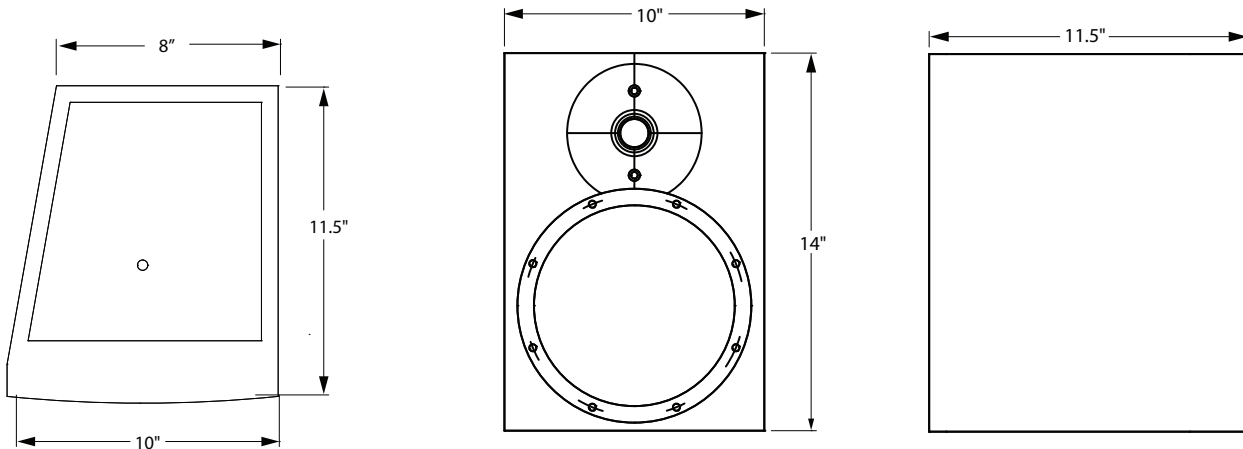

○ = 5/16" - 18 Threaded Rigging Point

