

# TA5002-R TIME-ALIGN®

## APPLICATIONS

Portable Sound Reinforcement      Drum Monitor  
Portable DJ Systems                  Electronic Keyboards  
Theatrical Sound Reinforcement

## DESCRIPTION

The TA5002-R is a portable full range loudspeaker system offering both high fidelity and high efficiency. The Time-Aligned™ studio quality sound provides detail and clarity not found in other designs. The TA5002-R is made from durable birch plywood with a black textured finish. A black coated steel grille, steel stand adapter and recessed handles make the TA5002-R an ideal choice for almost all portable sound reinforcement applications. The TA5002-R produces high definition high impact sound over its wide angle making audience coverage easy and effective in a variety of venues. A compact loudspeaker, engineered for exceptional mid and far field performance it is well known for exceptional fidelity and its surprisingly high output capability.

Useful for foreground and live sound applications, it excels in speech projection and small PA systems. With its fidelity, size and output its perfect for large multi channel 5.1 presentations systems. In larger systems the TA5002-R is highly effective as a fill, side fill or delay speaker. The addition of a Bag End subwoofer will expand its capabilities for more demanding applications.

Fly points and an optional Yoke-U-bracket allow the TA5002-R to be easily installed and aimed in a multitude of applications.



## SPECIFICATIONS

### System Type:

2-way vented 3.4 ft<sup>3</sup>

### Enclosure:

18 mm 13-ply birch plywood

### Finish:

Black Ro Tex™ true water born environmental finish

### Grille:

16 Gauge black powder coated perforated steel

### Low Frequency Components:

E-15 15" Transducer, 2.5" Voice coil, 80 oz Magnet

### High Frequency Components:

ZE-250 1" Exit compression driver, 2" Titanium diaphragm, 24 oz magnet, Exponential waveguide

### Input Connector:

Dual Neutrik® speakON

### Internal Amplification:

Optional self powered

### Hardware:

2 - Recessed handles  
35 mm Stand Adapter  
Optional fly points

### Fly Points Safe Working Load:

200 lbs Upper most rigging points

### Crossover Type:

Passive Time-Align® equalizer type at 1.7 kHz

### Time Offset Between Driver:

< ± 25 Microseconds

### Sensitivity:

101 dB SPL (2.83 V @ 1 m)

### Frequency Response:

50 Hz to 19 kHz ±3 dB

### Low Frequency Limit:

43 Hz

### Maximum Calculated Continuous Acoustic Output:

127 dB SPL @ 1 m

### Power Handling:

400 W continuous (IEC)  
800 W program

### Recommended Amplifier Power:

400 to 800 W at rated impedance

### Rated Impedance:

8 ohms

### Coverage Pattern:

90 degrees horizontal (-6 dB)  
40 degrees vertical (-6 dB)

### Recommended High Pass Filter:

50 Hz

### Polarity:

A positive asymmetrical signal applied to the + terminal will result in a positive asymmetrical acoustical pressure

### Dimensions:

27" h x 22" w x 18" d  
69 cm x 56 cm x 46 cm  
Trapezoidal – 8 degree taper per side

### Weight:

80 lbs  
32 kg

### Custom Finishes:

Optional custom finishes include white, unfinished ready to paint and outdoor weather treatment.

TIME-ALIGN®, TIME-ALIGNED™ and TIME-ALIGNMENT™ are trademarks of E.M. Long Associates.  
BAG END® is a registered trademark of Bag End, Inc.

# TA5002-R TIME-ALIGN®

## ABOUT TIME-ALIGN® TECHNOLOGY

Time-Align® assures that the fundamental and overtones of a complex, transient, acoustical signal are presented to the listener in the same relationship as the electrical signal at the input terminals of the loudspeaker. The conventional loudspeaker spreads out the sound in time. When a rapid series of transients occur the results are blurring and lost detail. With Time-Align®, a transient is presented as a tight package of energy, with the same time relationships as the natural sound. This means that a rapid series of transients will be heard clearly.



True Time-Alignment™ requires much more than just physically lining up the loudspeaker components. It requires consideration of the driver placement, driver delay and adjustment of the crossover delay parameters. This achieves the precise simultaneous acoustical arrival time of each driver throughout the crossover region.

The first Time-Aligned™ Loudspeaker was invented by EM Long Associates in 1976 utilizing the Time-Align® generator invented and built by Ronald Wickersham. In 1980 Bag End® incorporated Time-Align® technology into our full range loudspeaker systems. Along with state-of-the-art laboratory instruments, the proprietary Time-Align® generator is still in use today to verify the time domain performance of our loudspeaker systems. When comparing a genuine Bag End® Time-Aligned™ loudspeaker system to any other, our technology and design is easy to hear and appreciate. The dramatic clarity, realism, and overall pleasant sound of our Time-Aligned™ systems are well noted worldwide.

## ABOUT OUR RO TEX™ FINISH

The durable Ro Tex™ finish is found on Bag End™ "R" series or Road cabinets. Ro Tex™ is a water base, environmentally safe finish that is made in Europe and is

uniquely strong and long lasting. As it solidifies and attaches to the wooden cabinet it bonds with the wood to make a super hard permanent finish. It is lightly textured offering both an attractive and rugged finish.

## ABOUT BAG END® LOUSPEAKERS

Bag End loudspeakers began in 1976 in a small shop by people dedicated to the pursuit of making high quality loudspeaker systems. Over the decades Bag End® has employed the very best construction techniques and innovative acoustical designs into their products. The ground breaking introductions of the Time-Align® and ELF™ Technologies into sound reinforcement and studio monitor loudspeakers in the 1980's was followed by Minima One™ self-powered systems and the highly unique E-Trap™, electronic bass trap. Over the decades, Bag End® has been a leader in providing uniquely good sounding products and extraordinary service to our customers world wide.

## DIMENSIONS

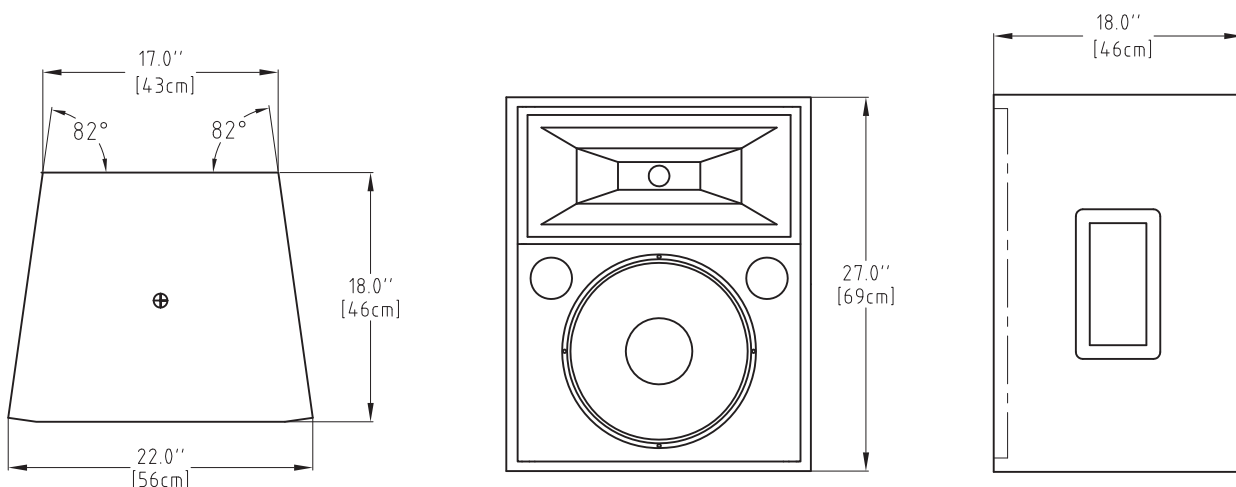

⊕ = Center of Gravity

