

IPS12E-I INFRASUB™

SELF-POWERED & SELF INFRA™ PROCESSED

APPLICATIONS

Laboratory Reference System	House of Worship
Recording Studio and Mastering	Theatrical Sound Reinforcement
Post Production and Screening Room	Installed Audio-Visual Systems
Restaurant Foreground Music Systems	Nightclub Installation

DESCRIPTION

The IPS12E-I is a self-powered and internally Infra™ processed single 12" bass system designed for permanent installation. The internal Minima 7™ amplifier and Infra™ processing provides for convenient implementation and wiring. The internal Infra™ integrator, amplifier and loudspeaker process the full range signal into a flat response low frequency acoustic output. The Dynamic Filter™ protection threshold is internally preset to eliminate distortion or accidental overload. This insures the maximum output and robust system protection with virtually no audible effect.

The audio input includes two balanced summing inputs and a direct through output, providing high common mode rejection, to eliminate noise often present in systems with less optimized grounding and wiring schemes. Includes connection for optional REMCON-2, remote dynamic filter threshold indicator.



SPECIFICATIONS

System Type:

Infrasub™ sealed chamber 1.4 ft³!3

Enclosure:

18 mm 13-ply birch plywood

Finish:

Black Ro Tex™ true water born environmental finish

Grille:

16 Gauge black powder coated perforated steel

Low Frequency Components:

EL-12B 12" Extended transducer, Infra™ cone, 2.5" Voice coil, 80 oz Magnet

Input Connector:

2 XLR summing inputs w/ one XLR male loop through

Internal Amplification:

Minima 7™

Input Impedance:

10K ohms

Input CAL Sensitivity:

+4 dBu

Maximum Continuous Amplifier Power:

750 W

LED Indicators:

Green - On
Yellow - Dynamic filter threshold

Mains Voltage Requirements:

Auto sensing
100 / 120 / 240 V

Mains Current Requirements:

2.3 A @ 120 V
1.2 A @ 240 V

Hardware:

Optional fly points
Optional steel yoke U-bracket

Fly Points Safe Working Load:

200 lbs.

Crossover Type:

Internal Infra™ integrator inside

Frequency Response:

8 Hz to 95 Hz ±3 dB

Low Frequency Limit:

8 Hz

Maximum Calculated Continuous Acoustic Output:

Half Space @ 1 Meter
10 Hz - 81 dB SPL
20 Hz - 93 dB SPL
40 Hz - 105 dB SPL
80 Hz - 116 dB SPL

Polarity:

A positive asymmetrical signal applied to pin 2 will result in a positive asymmetrical acoustical pressure

Dimensions:

15" h x 18" w x 15" d
39 cm x 46 cm x 39 cm

Weight:

40 lbs
18 kg

Other Options:

REMCN-2 Optional remote Dynamic Filter threshold indicator

Custom Finishes:

Optional custom finishes include white or unfinished ready to paint.

INFRA™, INFRASUB™, MINIMA 7™ and DYNAMIC FILTER™ are trademarks of Modular Sound Systems, Inc.
BAG END® is a registered trademark of Bag End, Inc.



IPS12E-I INFRASUB™

ABOUT INFRASUB™ TECHNOLOGY

Almost all designs and specifications for subwoofer systems are fixated on the frequency response domain. However, the impression of power and quality of a loudspeaker is equally related to the time domain. The long wavelengths associated with low frequencies make this particularly true with subwoofers. Likewise, the maximum SPL is not a very reliable way to judge the impact of a subwoofer. A poor time domain performer will not have the same impact or natural musically connected sound as a Time-Aligned™ Infra™ system. The reason that an Infra™ subwoofer sounds dramatically better is because of their superior time domain performance, as well as their extended low frequency response. The Infra™ subwoofer maintains



the bass energy in a tight packet, aligned with the upper range signal, providing a greater body impact and a seamless musical connection with the main loudspeakers. Conventional subwoofer designs perform poorly in the time domain because designers have used methods that sacrifice the phase response for more control over the frequency response (e.g.: steep low pass filter slopes, vented speaker enclosures, and narrow bandwidth systems). With the Infra™ technique, we do not degrade the phase response while extending the frequency response.

While the Infra™ dual Integrator does function as the system crossover, it does so without using a conventional low pass filter. The Infra™ integrator applies an inverse electrical response to the acoustical response of the Infra™ loudspeaker in its sealed enclosure. This provides the extended frequency response while maintaining the hi fidelity sound quality associated with a sealed box design. This design approach requires the most amplifier power to be used at the lowest frequency, thus we implement the Dynamic Filter™ technology to protect the system from the bottom up, affecting the lowest frequency first and leaving the middle and upper bass unaffected. The Dynamic Filter™ is a complimentary technology to the Infra™ system taking unique advantage of the Infra™ design approach, to implement a reliable protection scheme that is transparent and inaudible to the listener.

When comparing a genuine Bag End® Infra™ loudspeaker system to any other, our technology and design is easy to hear and appreciate. The dramatic clarity, realism, and overall pleasant sound of an Infra™ system is well noted throughout the world.

ABOUT MINIMA 7™ AND INFRA™ SELF PROCESSING

Infra™ self processed systems incorporates our analog Infra™ dual integrator into the Minima 7™ input circuit. Infra™ Self Powered Systems accept a full range line level audio signal, and utilizes internal Infra™ processing to provide the extended low frequency acoustical response, as well as a uniform roll off, of the upper range of the subwoofer. The Dynamic Filter™ protection is included and preset to the amplifiers sensitivity, requiring no external setup. The Minima 7™ amplifier is both a high fidelity and a high efficiency amplifier. With efficiency well over 80%, it provides more power to the loudspeakers, and creates less heat in the amplifier. In real world applications there is practically no heat emitted from the amplifier and thus it requires no cooling fan. The universal AC power input automatically accepts 100, 120 or 240 volts allowing it to operate anywhere in the world.

DIMENSIONS

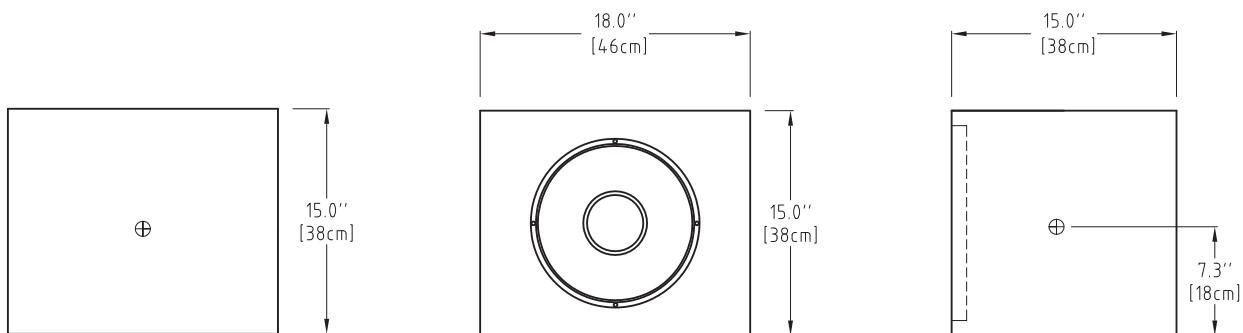

⊕ = Center of Gravity



IPS12E-1 INFRASUB™

SIDE VIEW

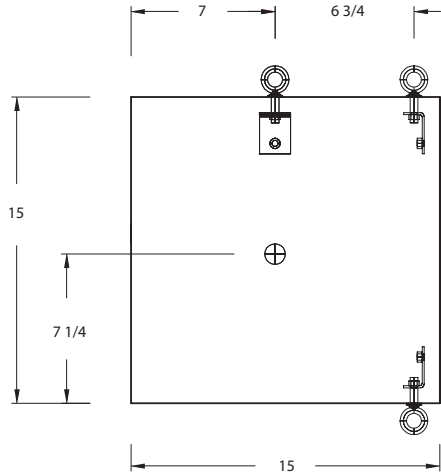

ISOMETRIC VIEW

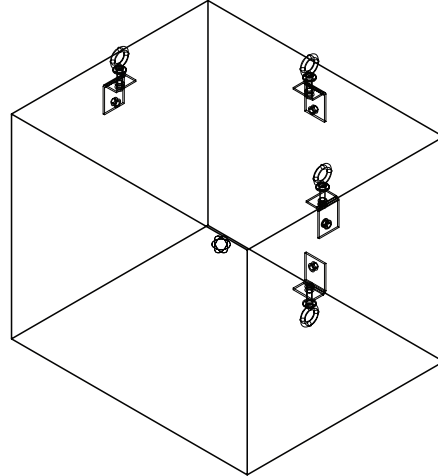

TOP VIEW

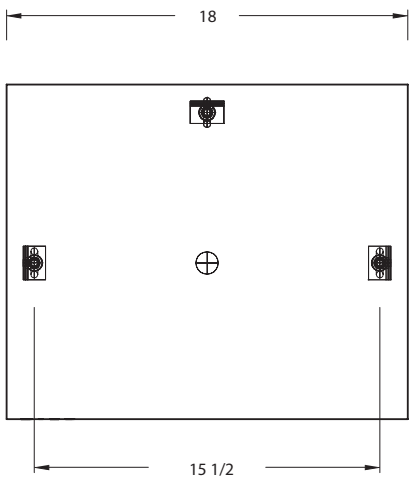

KEY

Center of Gravity: +

WARNINGS

Mounting and rigging loudspeakers requires experienced professionals. Improperly installed loudspeakers can result in property damage, personal injury, death and/or liability to the installing contractor.

FLYPOINTS

Optional hardware includes 5/16-18 threaded flypoints as shown.